

Ordering Information	2	Immersion Transducers	
Transducer Selections		Standard	16
Accuscan "S", Accuscan "R", Videoscan	3	Large Diameter, Reflector Mirrors, Search Tubes,	17
Contact Transducers		Slim Line, Pencil Case, Paintbrush	18
Fingertip	4	Normal Incidence Shear Wave Transducers	
Standard	5	Direct Contact, Delay Line	19
Dual Transducers		High Frequency Transducers	
Flushcase	6	Contact	20
Fingertip, Extended Range, Miniature Tip	7	Standard, SU/RM Case	21
Angle Beam Transducers and Wedges		Special Transducers	22-25
Miniature Screw-In	8	Test Blocks	26-27
CentraScan	9	Cables, Adaptors	28-29
Miniature Snap-in	9	Bubblers, Couplants	30
Standard	10	Test and Documentation	31
Snail Wedges, Accupath, O.P.	11		
Integral Angle, Shear Wave Wedges for Aluminum, Contoured Wedges	12		
Replaceable Delay Line Transducers			
Delay Line Transducers	13		
Sonopen [®] , Replaceable Delay Line Options	13		
Protected Face Transducers			
Standard	14		
High Temperature, Protective Wear Cap, Protective Wear Cap Options	15		

For direct access to the information listed in this transducer catalog,
please visit <http://www.panametrics-ndt.com>

Our policy is one of continuous product improvement incorporating our latest engineering innovations into current production. These engineering changes may cause pricing, dimensional or performance specifications to change without notice.

Part Number Information

Glossary of Transducer Part Numbers

Transducer Series

AxxxS	Accuscan "S"
AxxxR	Accuscan "R"
Cxxx	CentraScan
Dxxx	Dual
Vxxx	Videoscan
Xxxx	Miscellaneous

Transducer Type

1xx	Contact
15x	Normal Incidence Shear Wave
2xx	Videoscan Replaceable Delay Line
3xx	Immersion
4xx	Standard Angle Beam
5xx	Miniature Angle Beam
6xx	Protected Face
7xx	Dual

Fits Connector Styles

RB	Right Angle BNC
SB	Straight BNC
RM	Right Angle Microdot®
SM	Straight Microdot
RU	Right Angle UHF
SU	Straight UHF
RP	Right Angle Potted Cable Terminating in BNC Connectors
RPL1	Right Angle Potted Cable Terminating in Large Lemo® 1 Connectors

Contouring Delays

CC-R	Concave Radius
CX-R	Convex Radius

Contouring Wedges

AID	Axial Inside Diameter
AOD	Axial Outside Diameter
CID	Circumferential Inside Diameter
COD	Circumferential Outside Diameter

Focal Types (Immersion Transducers)

F	Spherical Focus
CF	Cylindrical Focus

Focal Designations

FPF	Flat Plate Focus
OLF	Optical Lens Focus
PTF	Point Target Focus

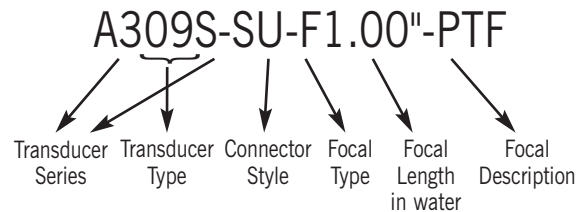
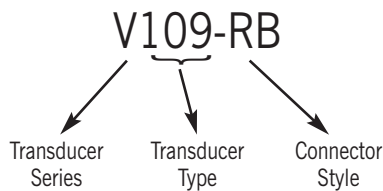

Glossary of Cable Part Numbers

Fits Connector Styles

B	BNC
U	UHF
L	Small Lemo 00
FL	Female Small Lemo 00
L1	Large Lemo 1
X	Unterminated
RL	Right Angle Small Lemo 00
M	Microdot
RM	Right Angle Microdot
LP	Lepre/Con
L	Small Lemo 00

Cable Grade

15	Low Impedance, 15 ohms
25	Low Impedance, 25 ohms
58	RG58/U, 50 ohms
62	RG62/U, 93 ohms
74	RG174/U, 50 ohms
188	RG188/U, 50 ohms
316	RG316/U, 50 ohms

Additional Cable Description

SSA	Stainless Steel Armor
W	Waterproof at Transducer End
WW	Waterproof at Both Ends
DS	Double Shielded
HD	Heavy Duty
HDAS	Silicone Sheath Over Cable
HDAP	PVC Sheath Over Cable

Letters Found After Connector Styles

D	Dual
H	Handle on Straight Microdot Connector
A	No boot on Microdot Connector

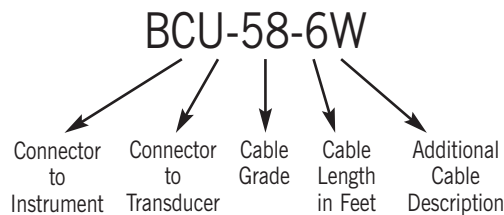

Microdot® is registered trademark of Microdot, Inc.
LEMO® is registered trademark of Interlemon Holding SA.

Transducer Selection

The transducer is one of the most critical components of any ultrasonic system. A great deal of attention should be paid to selecting the proper transducer for the application.

The performance of the system as a whole is of great importance. Variations in instrument characteristics and settings as well as material properties and coupling conditions play a major role in system performance.

We have developed three different series of transducers to respond to the need for variety. Each series has its own unique characteristics.

Transducer configuration also has an impact on system performance. Consideration should be given to the use of focused transducers, transducers with wear surfaces that are appropriate for the test material, and the choice of the appropriate frequency and element diameter.

The summaries below provide a general impression of the performance characteristics of each transducer series. While these guidelines are quite useful, each application is unique and performance will be dependent on electronics, cabling, and transducer configuration, frequency, and element diameter.

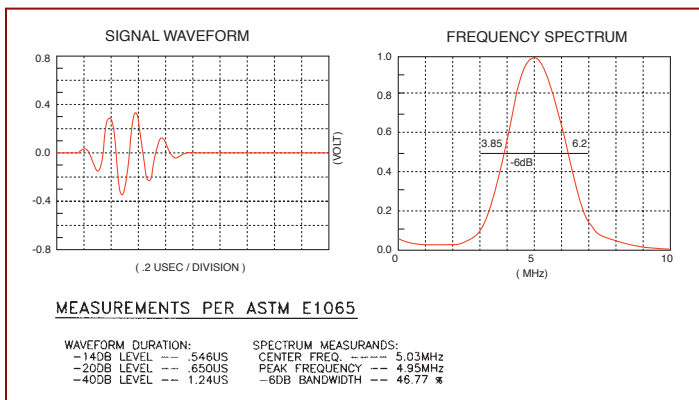

ACCUSCAN "S"

The Accuscan S series is intended to provide excellent sensitivity in those situations where axial resolution is not of primary importance. Typically this series will have a longer wave form duration and a relatively narrow frequency bandwidth.

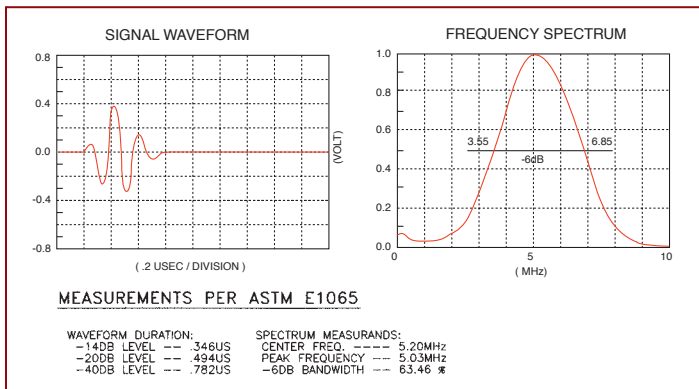

ACCUSCAN "R"

The Accuscan R series is designed to reduce excitation pulse and interface echo recovery time while maintaining good sensitivity at the transducer center frequency.

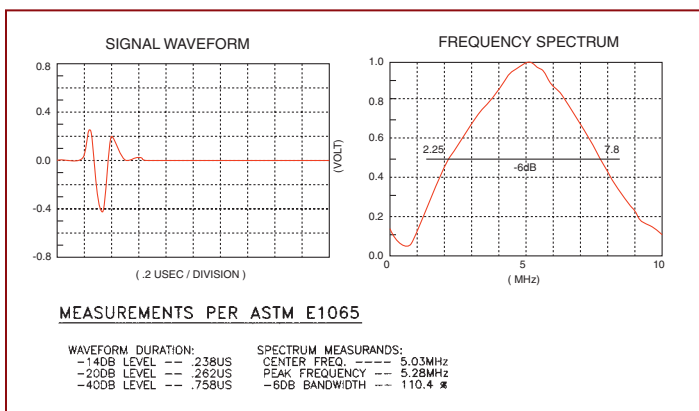

VIDEOSCAN

Videoscan transducers are untuned transducers that provide heavily damped broadband performance. They are the best choice in applications where good axial or distance resolution is necessary or in tests that require improved signal-to-noise in attenuating or scattering materials.

For more information on bandwidth and sensitivity versus resolution, please refer to the Technical Notes located on pages 32-39.

Note: For sample test forms of transducers that you are interested in purchasing or if you have questions, please contact us via phone, fax, or e-mail.

Contact Transducers

A contact transducer is a single element longitudinal wave transducer intended for use in direct contact with a test piece.

Advantages:

- ❖ Proprietary WC-5 wear plate increases durability, fracture resistance, and wear resistance
- ❖ All styles are designed for use in rugged industrial environments
- ❖ Close acoustic impedance matching to most metals
- ❖ Can be used to test a wide variety of materials
- ❖ Accuscan-S, Accuscan-R, and Videoscan series satisfy a variety of acoustic performance requirements
- ❖ Videoscan transducers offer improved signal-to-noise characteristics in highly attenuating or sound scattering materials
- ❖ Videoscan transducers offer improved main bang recovery for better near surface resolution

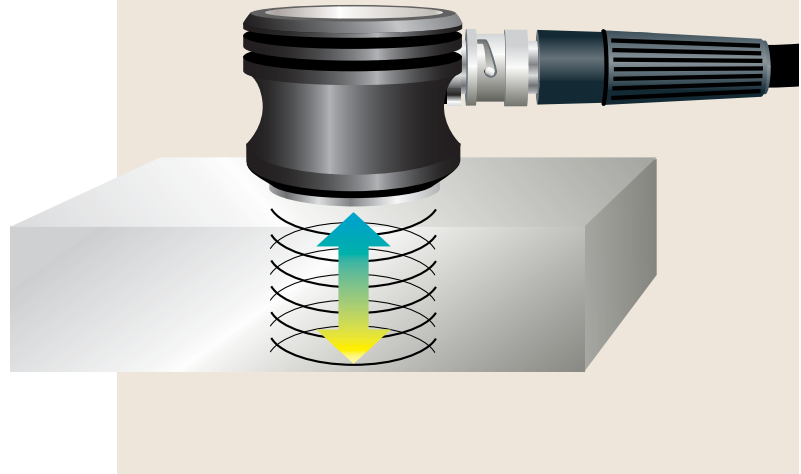

Applications:

- ❖ Straight beam flaw detection and thickness gaging
- ❖ Detection and sizing of delaminations
- ❖ Material characterization and sound velocity measurements
- ❖ Inspection of plates, billets, bars, forgings, castings, extrusions, and a wide variety of other metallic and non-metallic components

Fingertip Contact

- ❖ Units larger than 0.25" (6mm) are knurled for easier grip
- ❖ 303 stainless steel case
- ❖ Low profile for difficult-to-access surfaces
- ❖ Removable plastic sleeve for better grip available upon request at no additional charge, part number CAP4 for 0.25" (6mm) and CAP8 for 0.125" (3mm)
- ❖ Standard configuration is Right Angle and fits Microdot® connector.

Frequency MHz	Nominal Element Size		Transducer Part Numbers		
			ACCUSCAN-S	ACCUSCAN-R	VIDEOSCAN
0.5	1.00"	25mm	A101S-RM	A101R-RM	V101-RM
	0.75"	19mm	A102S-RM	A102R-RM	V102-RM
1.0	0.75"	19mm	A114S-RM	A114R-RM	V114-RM
	0.50"	13mm	A103S-RM	A103R-RM	V103-RM
	0.375"	10mm	A104S-RM	A104R-RM	V104-RM
2.25	1.00"	25mm	A105S-RM	A105R-RM	V105-RM
	0.75"	19mm	A106S-RM	A106R-RM	V106-RM
	0.50"	13mm	A125S-RM	A125R-RM	V125-RM
	0.375"	10mm	A133S-RM	A133R-RM	V133-RM
	0.25"	6mm	A180S-RM	A180R-RM	—
3.5	1.00"	25mm	A181S-RM	A181R-RM	V181-RM
	0.75"	19mm	A182S-RM	A182R-RM	V182-RM
	0.50"	13mm	A183S-RM	A183R-RM	V183-RM
	0.375"	10mm	A184S-RM	A184R-RM	—
5.0	0.25"	6mm	A107S-RM	A107R-RM	V107-RM
	1.00"	25mm	A108S-RM	A108R-RM	V108-RM
	0.75"	19mm	A109S-RM	A109R-RM	V109-RM
	0.50"	13mm	A126S-RM	A126R-RM	V126-RM
	0.375"	10mm	A110S-RM	A110R-RM	V110-RM
7.5	0.25"	6mm	—	—	V1091
	0.50"	13mm	A120S-RM	A120R-RM	—
	0.375"	10mm	A122S-RM	A122R-RM	V122-RM
	0.25"	6mm	A121S-RM	A121R-RM	V121-RM
10	0.50"	13mm	A111S-RM	A111R-RM	V111-RM
	0.375"	10mm	A127S-RM	A127R-RM	V127-RM
	0.25"	6mm	A112S-RM	A112R-RM	V112-RM
	0.125"	3mm	—	—	V129-RM
15	0.25"	6mm	A113S-RM	A113R-RM	V113-RM
20	0.125"	3mm	—	—	V116-RM

Standard Contact

- ❖ Comfort Fit Sleeves are designed to be easily held and to provide a steady grip while wearing gloves
- ❖ 303 stainless steel case
- ❖ Large element diameters for challenging applications and greater coverage
- ❖ Standard connector style is Right Angle BNC (RB), may be available in a Straight BNC (SB)

Frequency MHz	Nominal Element Size		Transducer Part Numbers		
			ACCUSCAN-S	ACCUSCAN-R	VIDEOSCAN
0.1	1.50"	38mm	—	—	V1011
			—	—	V1012
0.5	1.50"	38mm	A189S-RB	A189R-RB	V189-RB
	1.125"	29mm	A191S-RB	A191R-RB	V191-RB
	1.00"	25mm	A101S-RB	A101R-RB	V101-RB
1.0	1.50"	38mm	A192S-RB	A192R-RB	V192-RB
	1.125"	29mm	A194S-RB	—	V194-RB
	1.00"	25mm	A102S-RB	A102R-RB	V102-RB
	0.75"	19mm	A114S-RB	A114R-RB	V114-RB
	0.50"	13mm	A103S-RB	A103R-RB	V103-RB
2.25	1.50"	38mm	A195S-RB	A195R-RB	V195-RB
	1.125"	29mm	A197S-RB	A197R-RB	V197-RB
	1.00"	25mm	A104S-RB	A104R-RB	V104-RB
	0.75"	19mm	A105S-RB	A105R-RB	V105-RB
	0.50"	13mm	A106S-RB	A106R-RB	V106-RB
	0.25"x1"	6x25mm	A188S-RB*	A188R-RB*	—
3.5	1.00"	25mm	A180S-RB	A180R-RB	V180-RB
	0.75"	19mm	A181S-RB	A181R-RB	V181-RB
	0.50"	13mm	A182S-RB	A182R-RB	V182-RB
5.0	1.00"	25mm	A107S-RB	A107R-RB	V107-RB
	0.75"	19mm	A108S-RB	A108R-RB	V108-RB
	0.50"	13mm	A109S-RB	A109R-RB	V109-RB
7.5	0.50"	13mm	A120S-RB	A120R-RB	V120-RB
	0.50"	13mm	A111S-RB	A111R-RB	V111-RB

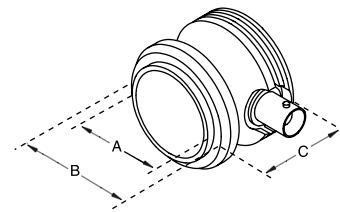

Nominal Element Size	(A)	(B)	(C)
1.50"*	1.75"	2.23"	1.25"
1.125"	1.38"	1.79"	1.25"
1.00"	1.25"	1.60"	1.25"
0.25" x 1.00"	1.25"	1.60"	1.25"
0.75"	1.00"	1.37"	1.25"
0.50"	0.63"	1.16"	1.25"

1 inch = 25.4mm

*V1011 and V1012 housed in different cases.

*Per ASTM Standard A-418

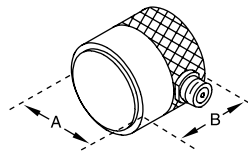

Nominal Element Size	(A)	(B)
1.00"	1.25"	0.63"
0.75"	1.00"	0.63"
0.50"	0.70"	0.63"
0.375"	0.53"	0.50"
0.25"	0.35"	0.42"
0.125"	0.25"	0.38"

1 inch = 25.4mm

Dual Element Transducers

A dual element transducer consists of two crystal elements housed in the same case, separated by an acoustic barrier. One element transmits longitudinal waves, and the other element acts as a receiver.

Contact us for information on transducers for all 26, 36 and 37 series thickness gages (such as the D790).

Advantages:

- ❖ Improves near surface resolution
- ❖ Eliminates delay line multiples for high temperature applications
- ❖ Couples well on rough or curved surfaces
- ❖ Reduces direct back-scattering noise in coarse grained or scattering materials
- ❖ Ideal for low temperature applications
- ❖ Combines penetration capabilities of a lower frequency single element transducer with the near surface resolution capabilities of a higher frequency single element transducer
- ❖ Can be contoured to conform to curved parts

Applications:

- ❖ Remaining wall thickness measurement
- ❖ Corrosion/erosion monitoring
- ❖ Weld overlay and cladding bond/disbond inspection
- ❖ Detection of porosity, inclusions, cracks, and laminations in castings and forgings
- ❖ Crack detection in bolts or other cylindrical objects

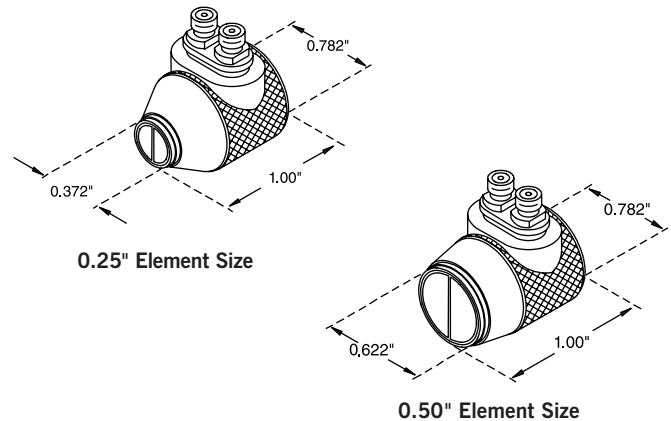
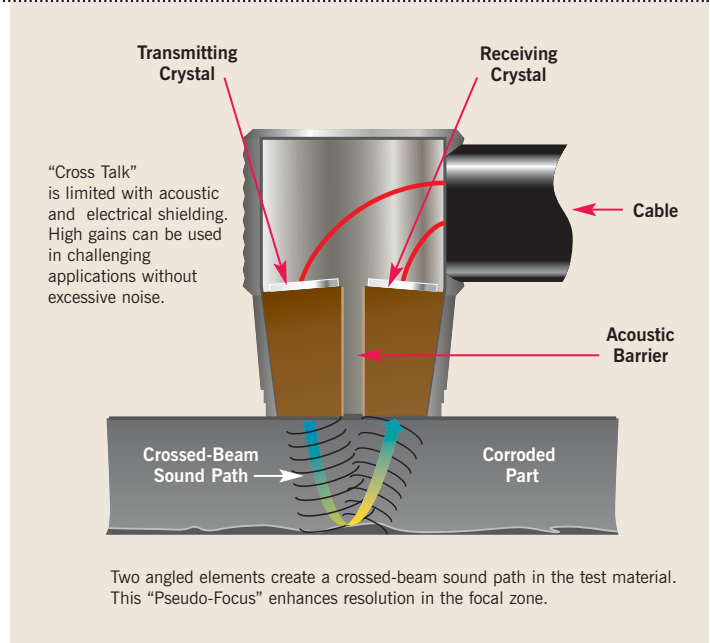

Flush Case Duals

- ❖ Metal wear ring extends transducer life
- ❖ Wear indicator references when transducer face needs resurfacing
- ❖ Knurled, 303 stainless steel case
- ❖ Replaceable cable design (special dual cables with strain relief available)

Frequency MHz	Nominal Element Size	Transducer Part Numbers
1.0	0.50" 13mm	DHC703-RM
2.25	0.50" 13mm	DHC706-RM
	0.25" 6mm	DHC785-RM
5.0	0.50" 13mm	DHC709-RM
	0.25" 6mm	DHC711-RM
10	0.25" 6mm	DHC713-RM

Note: Order replaceable cables separately, BCMD-316-5F, L1CMD-316-5F.



Fingertip Duals

- ❖ Highest temperature withstand capability*
- ❖ Knurled case, except the 0.25" (6mm) element size
- ❖ High-strength flexible 6' (1.8m) potted cable (fits BNC or Large Lemo® 1 connectors)

Frequency MHz	Nominal Element Size		Transducer Part Numbers	
			Fits BNC Connector	Fits Large Lemo Connector
1.0	0.75"	19mm	D714-RP	D714-RPL1
	0.50"	13mm	D703-RP	D703-RPL1
2.25	0.75"	19mm	D705-RP	D705-RPL1
	0.50"	13mm	D706-RP	D706-RPL1
	0.375"	10mm	D771-RP	D771-RPL1
	0.25"	6mm	D785-RP	D785-RPL1
	0.25"	6mm	D785-RP	D785-RPL1
3.5	0.75"	19mm	D781-RP	D781-RPL1
	0.50"	13mm	D782-RP	D782-RPL1
	0.375"	10mm	D783-RP	D783-RPL1
	0.25"	6mm	D784-RP	D784-RPL1
5.0	0.75"	19mm	D708-RP	D708-RPL1
	0.50"	13mm	D709-RP	D709-RPL1
	0.375"	10mm	D710-RP	D710-RPL1
	0.25"	6mm	D711-RP	D711-RPL1
7.5	0.50"	13mm	D720-RP	D720-RPL1
	0.25"	6mm	D721-RP	D721-RPL1
10	0.50"	13mm	D712-RP	D712-RPL1
	0.25"	6mm	D713-RP	D713-RPL1

* Maximum temperature withstand capability is 800°F (427°C) for 5.0MHz and below; 350°F (177°C) for 7.5MHz and 10MHz. Recommended duty cycle for surface temperatures from 200°F (93°C) to 800°F (427°C) is ten seconds maximum contact followed by a minimum of one minute air cooling.

Extended Range Duals

- ❖ Shallow roof angles provide greater sensitivity to deep flaws, back walls, and other reflectors, 0.75" (19mm) and beyond in steel
- ❖ Can be used for high temperature measurements when delay lines are unacceptable*
- ❖ High-strength flexible 6' (1.8m) potted cable with BNC connectors

Frequency MHz	Nominal Element Size		Roof Angle (degrees)	Transducer Part Numbers
2.25	1.00"	25mm	0	D7079
	0.50"	13mm	0	D7071
	0.50"	13mm	1.5	D7072
	0.50"	13mm	2.6	D7074
	0.50"	13mm	3.5	D7073
5.0	1.00"	25mm	0	D7080
	0.50"	13mm	0	D7075
	0.50"	13mm	1.5	D7076
	0.50"	13mm	2.6	D7078
	0.50"	13mm	3.5	D7077

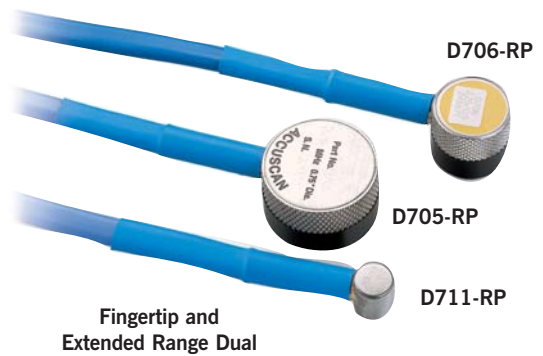

Fingertip and Extended Range Dual

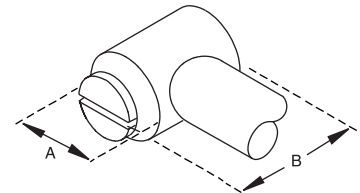

Nominal Element Size	(A)	(B)
1.00"	1.25"	0.75"
0.75"	1.00"	0.75"
0.50"	0.70"	0.75"
0.375"	0.53"	0.62"
0.25"	0.35"	0.54"

1 inch = 25.4mm

Miniature Tip Dual

- ❖ Small tip diameter provides better coupling on curved surfaces
- ❖ Low profile allows for better access in areas of limited space
- ❖ Replaceable cable available for use with any commercially available flaw detector

Frequency MHz	Tip Diameter	Nominal Element Size	Transducer Part Number
5.0	0.20" 5mm	0.15" 3.8mm	MTD705

Note: Order replaceable cables separately, BCLPD-78-5 and L1CLPD-78-5.

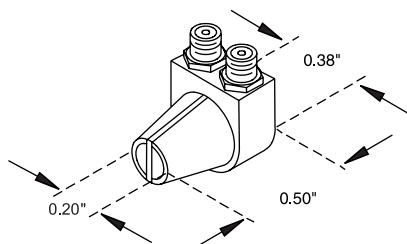

Miniature Tip Dual

Angle Beam Transducers

Angle beam transducers are single element transducers used with a wedge to introduce a refracted shear wave or longitudinal wave into a test piece.

Advantages:

- ❖ Three-material design of our Accupath wedges improves signal-to-noise characteristics while providing excellent wear resistance
- ❖ High temperature wedges available for in-service inspection of hot materials
- ❖ Wedges can be customized to create nonstandard refracted angles
- ❖ Available in interchangeable or integral designs
- ❖ Contouring available
- ❖ Wedges and integral designs are available with standard refracted angles in aluminum

Applications:

- ❖ Flaw detection and sizing
- ❖ Videoscan transducers can be used for time of flight diffraction techniques
- ❖ Inspection of pipes, tubes, forgings, castings, as well as machined and structural components for weld defects or cracks

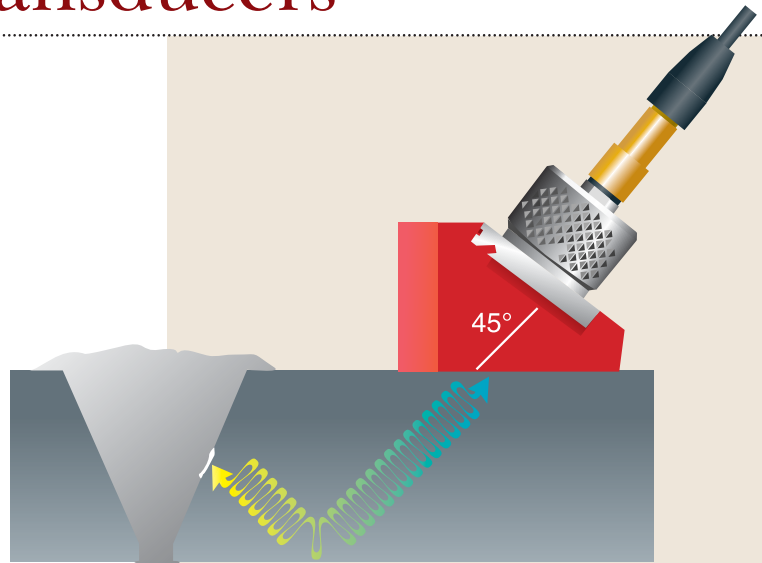

Miniature Angle Beam Transducers and Wedges are used primarily for flaw detection of welds. Their design allows them to be easily scanned back and forth and provides a short approach distance.

Miniature Screw-In Transducers and Wedges

- ❖ Screw-in design 303 stainless steel case
- ❖ Small wedge footprint
- ❖ Short approach distance
- ❖ Pointed toe design allows transducer rotation even when the nose is touching a weld crown
- ❖ Special wedge design for use with 10MHz transducer
- ❖ Transducers are color coded by frequency



Nominal Element Size	Frequency MHz	Transducer Part Numbers			Wedge Part Numbers		
		ACCUSCAN-S	VIDEOSCAN	Accupath*	Surface Wave 90°	High Temp* 500°F (260°C)	Very High Temp* 900°F (480°C)
0.50" 13mm	1.0	A539S-SM	V539-SM	ABWM-5T- x	ABWML-5T-90°	ABWHT-5T- x	ABWVHT-5T- x
	2.25	A540S-SM	V540-SM				
	3.5	A545S-SM	V545-SM				
	5.0	A541S-SM	V541-SM				
	10	A547S-SM	V547-SM	ABWM-5ST- x	ABWML-5ST-90°	—	—
0.375" 10mm	1.5	A548S-SM	—	ABWM-7T- x	ABWML-7T-90°	ABWHT-7T- x	ABWVHT-7T- x
	2.25	A549S-SM	V549-SM				
	3.5	A550S-SM	V550-SM				
	5.0	A551S-SM	V551-SM				
	10	A552S-SM	V552-SM	ABWM-7ST- x	ABWML-7ST-90°	—	—
0.25" 6mm	2.25	A542S-SM	V542-SM	ABWM-4T- x	ABWML-4T-90°	ABWHT-4T- x	ABWVHT-4T- x
	3.5	A546S-SM	V546-SM				
	5.0	A543S-SM	V543-SM	ABWM-4ST- x	ABWML-4ST-90°	—	—
	10	A544S-SM	V544-SM				

*Wedges are available in standard refracted shear wave angles of 30°, 35°, 45°, 60°, and 70° in steel as measured at 5.0MHz. x indicates degrees. Please specify upon ordering.

CentraScan

In addition to having the same advantages and case style as the Miniature Screw-In Transducers, the piezo-composite element CentraScan Series transducers provide the following features:

- ❖ excellent sensitivity
- ❖ high signal-to-noise ratio in difficult to penetrate materials
- ❖ exceptional acoustic matching in plastics and other low impedance materials

Nominal Element Size	Frequency MHz	Transducer Part Numbers	Wedge Part Numbers			
			CENTRASCAN	Accupath*	Surface Wave 90°	High Temp* 500°F (260°C)
0.50" 13mm	2.25 5.0	C540-SM	ABWM-5T- x	ABWML-5T-90°	ABWHT-5T- x	ABWVHT-5T- x
		C541-SM				
0.375" 10mm	2.25 5.0	C549-SM	ABWM-7T- x	ABWML-7T-90°	ABWHT-7T- x	ABWVHT-7T- x
		C551-SM				
0.25" 6mm	2.25 5.0	C542-SM	ABWM-4T- x	ABWML-4T-90°	ABWHT-4T- x	ABWVHT-4T- x
		C543-SM				

*Wedges are available in standard refracted shear wave angles of 45°, 60°, and 70° in steel as measured at 5.0MHz. x indicates degrees. Please specify upon ordering.

Nominal Element Size	Nominal Element Size											
	0.50"				0.375"				0.25"			
	(A)	(B)	(C)	(D)	(A)	(B)	(C)	(D)	(A)	(B)	(C)	(D)
30°	0.72"	1.22"	0.77"	0.54"	0.62"	1.03"	0.65"	0.42"	0.49"	0.66"	0.45"	0.23"
45°	0.85"	1.31"	0.77"	0.49"	0.76"	1.14"	0.65"	0.41"	0.53"	0.74"	0.45"	0.24"
60°	1.00"	1.66"	0.77"	0.66"	0.87"	1.41"	0.65"	0.52"	0.63"	0.95"	0.45"	0.32"
70°	1.00"	1.82"	0.77"	0.73"	0.92"	1.52"	0.65"	0.51"	0.66"	1.08"	0.45"	0.36"
90°	1.25"	1.84"	0.77"	—	1.00"	1.48"	0.65"	—	0.83"	1.13"	0.45"	—

*Wedge dimensions for 10MHz transducers are slightly different, please consult us for details.

Note: Dimensions for 0.375" only apply to Miniature Screw-In Wedges.

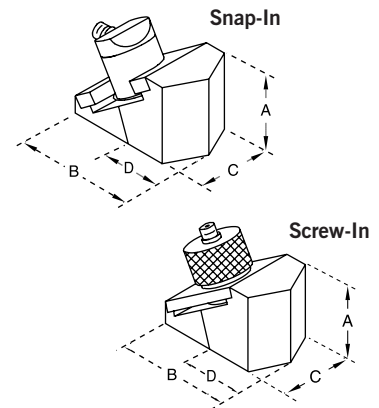

Miniature Snap-In Transducers and Wedges

- ❖ Snap-In design 303 stainless steel case
- ❖ Pointed toe design allows transducer rotation even when the nose is touching a weld crown
- ❖ Special wedge design for 10MHz transducer
- ❖ Special snap-in ring provides uniform coupling while allowing rotation of the transducer to keep the cable away from interfering structures
- ❖ Transducers available in Accuscan-S, Accuscan-R, and Videoscans

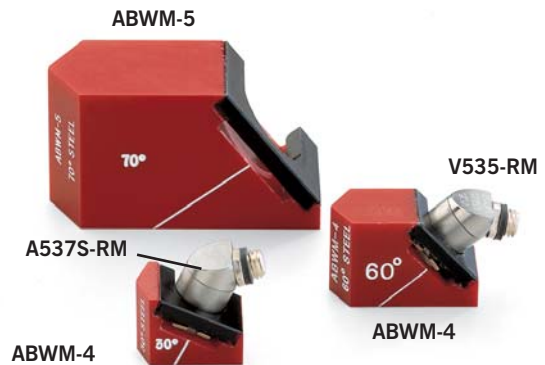

Nominal Element Size	Frequency MHz	Transducer Part Numbers			Wedge Part Numbers			
		ACCUSCAN-S	ACCUSCAN-R	VIDEOSCAN	Accupath*	Surface Wave 90°	High Temp* 500°F (260°C)	Very High Temp* 900°F (480°C)
0.50" 13mm	2.25	A534S-RM	A534R-RM	V534-RM	ABWM-5- x	ABWML-5-90°	ABWHT-5- x	ABWVHT-5- x
	5.0	A536S-RM	A536R-RM	V536-RM	ABWM-5- x	ABWML-5-90°	ABWHT-5- x	ABWVHT-5- x
	10	A538S-RM	A538R-RM	V538-RM	ABWM-5S- x	ABWML-5S-90°	—	—
0.25" 6mm	2.25	A533S-RM	A533R-RM	V533-RM	ABWM-4- x	ABWML-4-90°	ABWHT-4- x	ABWVHT-4- x
	5.0	A535S-RM	A535R-RM	V535-RM	ABWM-4- x	ABWML-4-90°	ABWHT-4- x	ABWVHT-4- x
	10	A537S-RM	A537R-RM	V537-RM	ABWM-4S- x	ABWML-4S-90°	—	—

*Wedges are available in standard refracted shear wave angles of 30°, 35°, 45°, 60°, and 70° in steel as measured at 5.0MHz. Please specify upon ordering.

See page 25 for low frequency, high angle wedge options.

Standard Angle Beam Transducers and Wedges

- ❖ Large element size allows for inspection of thicker components and provides a large scanning index
- ❖ Transducers available in Accuscan-S, Accuscan-R, and Videoscan Series
- ❖ Accupath and High Temperature style wedges available
- ❖ Threaded brass screw receptacles ensure firm anchoring of the transducer onto the wedge
- ❖ Available in frequencies as low as 0.5MHz and 1.0MHz
- ❖ Captive screws included with the transducer

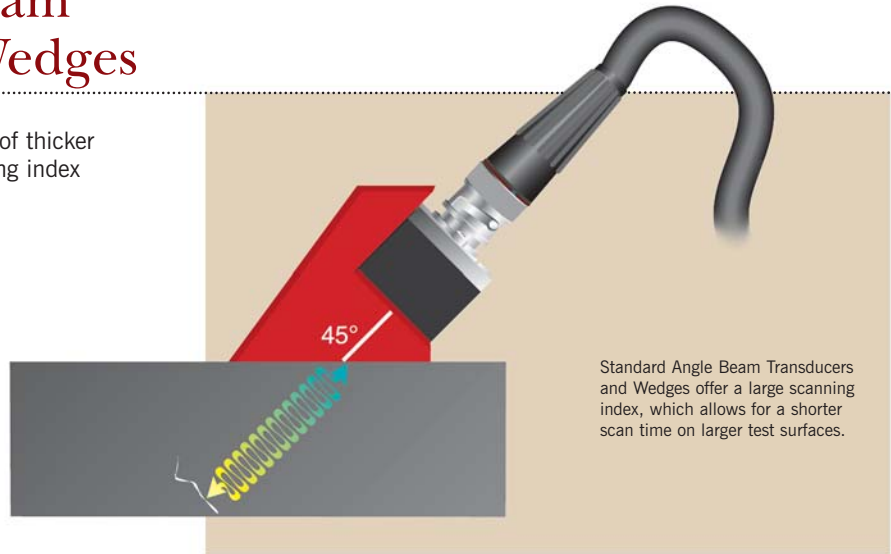

Nominal Element Size	Frequency MHz	Transducer Part Numbers			Wedge Part Numbers			
		ACCUSCAN-S	ACCUSCAN-R	VIDEOSCAN	Accupath*	Surface Wave 90°	High Temp* 500°F (260°C)	Very High Temp* 900°F (480°C)
1.00" 25mm	0.5	A414S-SB	A414R-SB	V414-SB	ABWS-3-	ABWSL-3-90	ABWHT-3-	ABWVHT-3-
	1.0	A407S-SB	A407R-SB	V407-SB				
	2.25	A408S-SB	A408R-SB	V408-SB				
	3.5	A411S-SB	—	—				
	5.0	A409S-SB	A409R-SB	V409-SB				
0.50" x 1.00" 13 x 25mm	0.5	A413S-SB	A413R-SB	V413-SB	ABWS-2-	ABWSL-2-90	ABWHT-2-	ABWVHT-2-
	1.0	A401S-SB	A401R-SB	V401-SB				
	2.25	A403S-SB	A403R-SB	V403-SB				
	3.5	A412S-SB	—	—				
	5.0	A405S-SB	A405R-SB	V405-SB				
0.50" 13mm	1.0	A402S-SB	A402R-SB	V402-SB	ABWS-1-	ABWSL-1-90	ABWHT-1-	ABWVHT-1-
	2.25	A404S-SB	A404R-SB	V404-SB				
	3.5	A415S-SB	—	—				
	5.0	A406S-SB	A406R-SB	V406-SB				

*Wedges are available in standard refracted shear wave angles of 30°, 45°, 60°, and 70° in steel as measured at 5.0MHz. Please specify upon ordering.

Diagram	Nominal Element Size												
	1.00"				0.50" x 1.00"				0.50"				
	(A)	(B)	(C)	(D)	(A)	(B)	(C)	(D)	(A)	(B)	(C)	(D)	
	30°	1.69"	2.15"	1.62"	1.15"	1.30"	1.30"	1.60"	0.76"	1.20"	1.42"	1.10"	0.83"
	45°	1.47"	1.96"	1.63"	0.97"	1.30"	1.41"	1.60"	0.78"	1.20"	1.31"	1.08"	0.70"
	60°	1.50"	2.18"	1.63"	1.00"	1.30"	1.50"	1.60"	0.67"	1.20"	1.48"	1.08"	0.68"
	70°	1.50"	2.47"	1.63"	1.13"	1.35"	1.77"	1.60"	0.85"	1.20"	1.58"	1.09"	0.68"
	90°	1.50"	2.50"	1.65"	0.44"	1.20"	1.34"	1.60"	—	1.20"	1.34"	1.00"	—

Dimension A = Wedge Height
Dimension D = Approach Distance

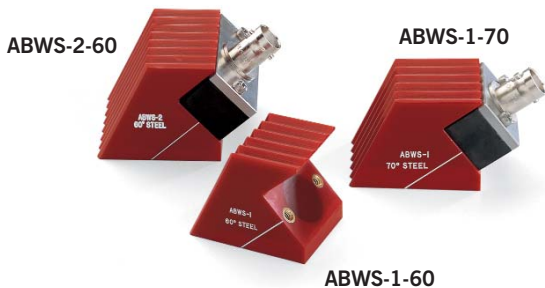

Nominal Element Size	(E)	(F)	(G)	(H)
1.00"	1.25"	0.63"	1.38"	1.65"
0.50" x 1.00"	0.73"	0.63"	1.31"	1.53"
0.50"	0.72"	0.63"	0.81"	1.02"

AWS Snail Wedges and Transducers

- ❖ Transducers and wedges meet or exceed the specifications as set forth by the AWS Code Section D1.1
- ❖ Snail transducers and wedges use industry accepted hole spacing
- ❖ Captive screws included with the transducer

Nominal Element Size	Frequency MHz	Transducer Part Numbers	Wedge Part Number*
0.625" x 0.625"	2.25	A430S-SB	ABWS-8-
0.625" x 0.75"		A431S-SB	
0.75" x 0.75"		A432S-SB	

* Wedges are available in standard refracted shear wave angles of 45°, 60°, and 70° in steel. Please specify upon ordering.

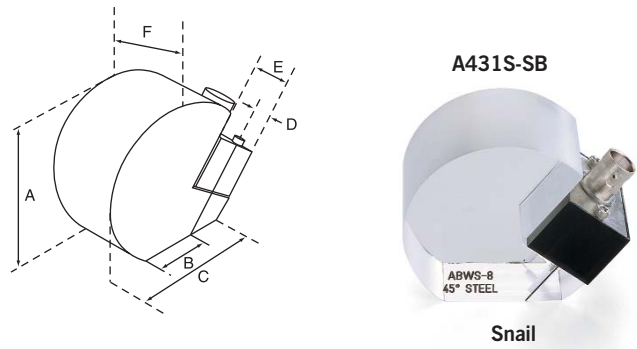

	(A)	(B)	(C)	(D)	(E)	(F)
45°	1.99"	0.885"	1.74"	0.50"	0.868"	1.25"
60°	1.98"	0.691"	1.97"	0.50"	0.907"	1.25"
70°	1.88"	0.771"	1.88"	0.50"	0.932"	1.25"

*Distance between screws (center to center) is 1.00".

AWS Accupath Angle Beam Wedges and Transducers

- ❖ Transducers and wedges meet or exceed the specifications as set forth by the AWS Code Section D1.1
- ❖ Accupath style wedges marked with a five line graticule to assist in locating the beam exit point
- ❖ Threaded brass screw receptacles ensure firm anchoring of the transducer onto the wedge
- ❖ Captive screws included with the transducer

Nominal Element Size	Frequency MHz	Transducer Part Numbers	Wedge Part Number*
0.625" x 0.625"	2.25	A420S-SB	ABWS-6-
0.625" x 0.75"		A421S-SB	
0.75" x 0.75"		A422S-SB	

*Wedges are available in standard refracted shear wave angles of 45°, 60°, and 70° in steel. Please specify upon ordering.

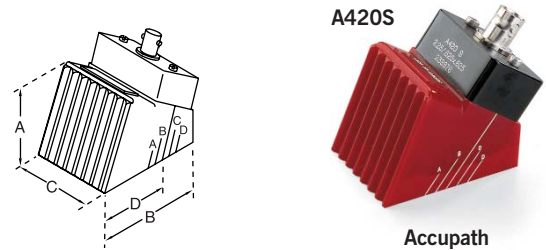

	(A)	(B)	(C)	(D)
45°	1.50"	1.96"	1.50"	0.90"
60°	1.68"	2.05"	1.50"	0.79"
70°	1.66"	2.20"	1.50"	0.96"

*Distance between screws (center to center) is 1.062".

O.P. Angle Beam Wedges and Transducers

- ❖ Transducer/Wedge combination features a low profile
- ❖ Short soundpath in wedge reduces signal attenuation
- ❖ Internally threaded joint between transducer case and connector resists breakage even under the most demanding conditions

Nominal Element Size	Frequency MHz	Transducer Part Numbers	Wedge Part Number*
0.25"	2.25	A5033	OP-4-
6mm	3.5	A5037	
	5.0	A5038	

*Wedges are available in standard refracted shear wave angles of 45°, 60°, and 70° in steel. Please specify upon ordering.

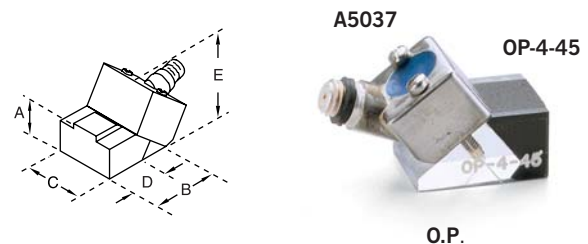

	(A)	(B)	(C)	(D)	(E)
45°	0.31"	0.57"	0.50"	0.31"	0.51"
60°	0.34"	0.69"	0.50"	0.36"	0.52"
70°	0.39"	0.79"	0.50"	0.43"	0.52"

*Distance between screws (center to center) is 0.375".

Integral Angle Beam Transducers

- ❖ Durable plastic wear surface extends transducer life and avoids scratching of critical components
- ❖ Small approach distance and overall transducer height make these an excellent choice for limited access applications
- ❖ Superior signal-to-noise characteristics for such a small integral transducer
- ❖ Finger ring included with Micro-Miniature-RM case style transducers

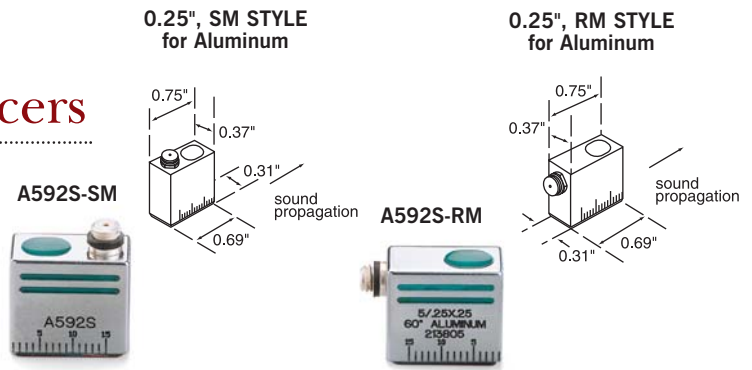

Transducer Case	Nominal Element Size	Frequency MHz	Material	Connector Style	Transducer Part Numbers			
					45°	60°	70°	90°
Miniature	0.25" x 0.25" 6 x 6mm	2.25	Steel	RM	A561S-RM	A562S-RM	A563S-RM	A564S-RM*
		5.0	Steel	RM	A571S-RM	A572S-RM	A573S-RM	A574S-RM*
		5.0	Aluminum	RM or SM	A591S	A592S	A593S	see note*
Micro-Miniature	0.187" x 0.187" 5 x 5mm	2.25	Steel	RM	A5050	—	—	A5053*
		5.0	Steel	RM	A5020	A5023	A5021	—
		5.0	Steel	SM	A5015	A5014	A5013	—
		10	Steel	SM	—	—	A5054	—
		5.0	Aluminum	SM	A5067	A5068	A5069	see note*

*A564S-RM, A574S-RM and A5053 create surface waves in steel and aluminum.

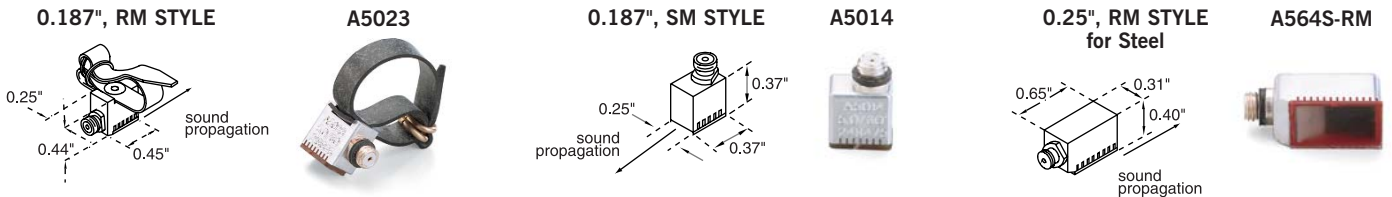

Shear Wave Wedges for Aluminum

- ❖ Compatible with our Miniature Screw-In, Snap-In, and Standard Angle Beam transducers

Transducer Case	Nominal Element Size		Wedge Part Numbers				
			30°	45°	60°	70°	90°
Screw-In	0.50"	13mm	ABWM-5053T	ABWM-5027T	ABWM-5028T	ABWM-5029T	ABWML-5041T
	0.375"	10mm	ABWM-7024T	ABWM-7025T	ABWM-7026T	ABWM-7027T	ABWML-7028T
	0.25"	6mm	ABWM-4086T	ABWM-4087T	ABWM-4088T	ABWM-4089T	ABWML-4074T
Snap-In	0.50"	13mm	ABWM-5053	ABWM-5027	ABWM-5028	ABWM-5029	ABWML-5041
	0.25"	6mm	ABWM-4086	ABWM-4087	ABWM-4088	ABWM-4089	ABWML-4074
Standard	1.00"	25mm	ABWS-3028	ABWS-3016	ABWS-3029	ABWS-3030	ABWSL-3039
	0.50" x 1.00"	13 x 25mm	ABWS-2021	ABWS-2022	ABWS-2023	ABWS-2024	ABWSL-2056
	0.50"	13mm	ABWS-1033	ABWS-1034	ABWS-1035	ABWS-1036	ABWSL-1045

Contoured Wedges

- ❖ Improves coupling on curved surfaces

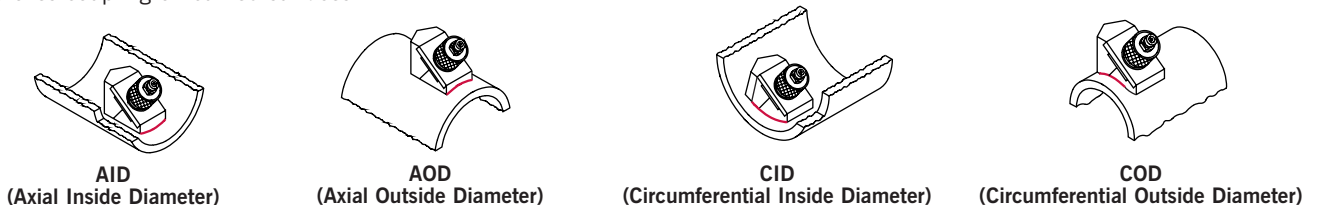

Replaceable Delay Line Transducers

A replaceable delay line transducer is a single element Videoscan transducer which has a case design configured for use with a replaceable delay line.

Advantages:

- ❖ Heavily damped transducer combined with the use of a delay line provides excellent near surface resolution
- ❖ Higher transducer frequency improves resolution
- ❖ Improves the ability to measure thin materials or find small flaws while using the direct contact method
- ❖ Contouring available to fit round parts

Applications:

- ❖ Precision thickness gaging
- ❖ Straight beam flaw detection
- ❖ Inspection of parts with limited contact areas

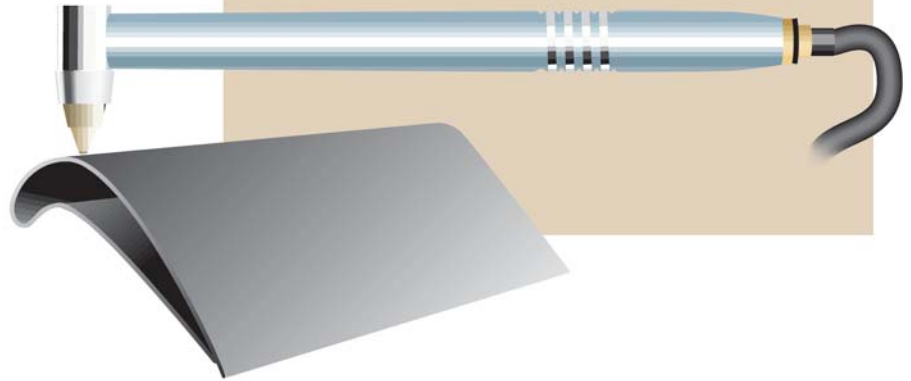

Sonopen® Transducer

- ❖ Focused replaceable delay line
- ❖ Extremely small tip diameter may improve performance on curved surfaces and small indentations
- ❖ Handle for easier positioning of transducer head

Delay Line Transducers

- ❖ Each transducer comes with a room temperature delay line and retaining ring
- ❖ High temperature and dry couple delay lines are available

Frequency MHz	Nominal Element Size	Transducer Part Numbers
2.25	0.25" 6mm	V204-RM
5.0	0.50" 13mm 0.25" 6mm	V206-RM V201-RM
10	0.25" 6mm 0.125" 3mm	V202-RM V203-RM
15	0.25" 6mm	V205-RM
20	0.125" 3mm	V208-RM

Frequency MHz	Nominal Element Size	Transducer Part Numbers		
		Straight Handle	Right Angle Handle	45° Handle
15	0.125" 3mm	V260-SM	V260-RM	V260-45

Sonopen Replacable Delay Lines		Spring Loaded Holder
0.080" Tip (2.0 mm)" DLP-3	0.60" Tip (1.5 mm) DLP-302	SLH-V260-SM

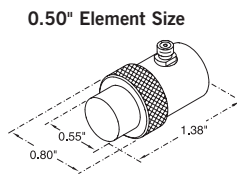
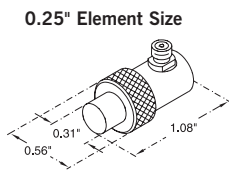
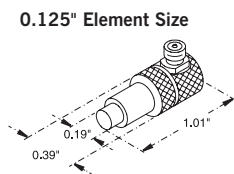

Replaceable Delay Line Options

Transducer Nominal Element Size	Standard Delay Line	Dry Couple Delay Line	Spare Retaining Ring	High Temperature		
				350°F Max (175°C)	500°F Max* (260°C)	Spring Loaded Holders
0.50" 13mm	DLH-2	DLS-2	DRR-2	DLHT-201	DLHT-2	2130
0.25" 6mm	DLH-1	DLS-1	DRR-1	DLHT-101	DLHT-1	2127 & DRR-1H
0.125" 3mm	DLH-3	DLS-3	DRR-3	DLHT-301	DLHT-3	2133 & DRR-3H

*For higher temperature delay lines, please consult us for details.

Protected Face Transducers

A protected face transducer is a single element longitudinal wave contact transducer that can be used with either a delay line, protective membrane, or protective wear cap.

Advantages:

- ❖ Provide versatility by offering removable delay line, protective wear cap, and protective membrane
- ❖ When the transducer is used alone (without any of the options), the epoxy wear face provides good acoustic impedance matching into plastics, many composites, and other low impedance materials
- ❖ Cases are threaded for easy attachment to the delay line, protective membrane, and wear cap options

Applications:

- ❖ Straight beam flaw detection
- ❖ Thickness gaging
- ❖ High temperature inspections
- ❖ Inspection of plates, billets, bars, and forgings

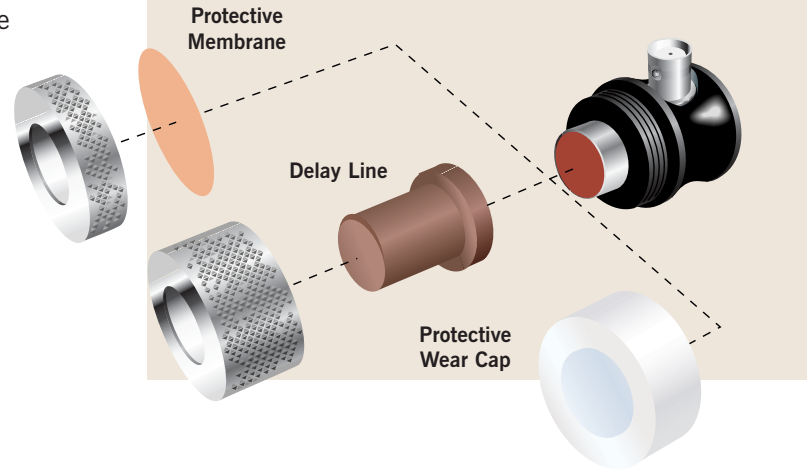

Standard Protected Face

- ❖ Comfort Fit Sleeves are designed to be easily held and provide steady grip while wearing gloves
- ❖ Standard connector style Right Angle BNC (RB), may be available in Straight BNC (SB)
- ❖ Transducer sold separately from the delay line, protective membrane, and wear cap options



Frequency MHz	Nominal Element Size		Transducer Part Numbers		
			ACCUSCAN - S	ACCUSCAN - R	VIDEOSCAN
0.5	1.50"	38mm	A689S - RB	A689R - RB	V689 - RB
	1.125"	29mm	A691S - RB	A691R - RB	V691 - RB
	1.00"	25mm	A601S - RB	A601R - RB	V601 - RB
1.0	1.50"	38mm	A692S - RB	A692R - RB	V692 - RB
	1.125"	29mm	A694S - RB	A694R - RB	V694 - RB
	1.00"	25mm	A602S - RB	A602R - RB	V602 - RB
	0.75"	19mm	A614S - RB	A614R - RB	V614 - RB
	0.50"	13mm	A603S - RB	A603R - RB	V603 - RB
2.25	1.50"	38mm	A695S - RB	A695R - RB	V695 - RB
	1.125"	29mm	A697S - RB	A697R - RB	V697 - RB
	1.00"	25mm	A604S - RB	A604R - RB	V604 - RB
	0.75"	19mm	A605S - RB	A605R - RB	V605 - RB
	0.50"	13mm	A606S - RB	A606R - RB	V606 - RB
3.5	1.00"	25mm	A680S - RB	A680R - RB	V680 - RB
	0.75"	19mm	A681S - RB	A681R - RB	V681 - RB
	0.50"	13mm	A682S - RB	A682R - RB	V682 - RB
5.0	1.00"	25mm	A607S - RB	A607R - RB	V607 - RB
	0.75"	19mm	A608S - RB	A608R - RB	V608 - RB
	0.50"	13mm	A609S - RB	A609R - RB	V609 - RB
10	0.50"	13mm	A611S - RB	A611R - RB	V611 - RB

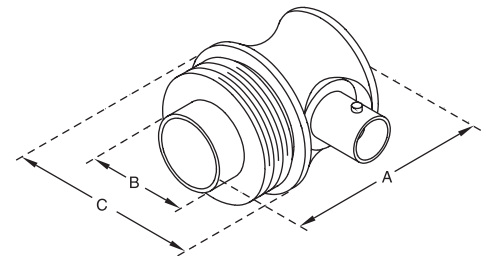

Nominal Element Size	(A)	(B)	(C)
1.50"	1.53"	1.75"	2.25"
1.125"	1.53"	1.38"	1.81"
1.00"	1.53"	1.25"	1.63"
0.75"	1.53"	0.99"	1.41"
0.50"	1.53"	0.63"	1.19"

1 inch = 25.4mm

High Temperature Delay Line Options

- ❖ Allows for intermittent contact with hot surfaces*
- ❖ Improves near surface resolution
- ❖ Improves coupling into difficult to penetrate composites and other low impedance materials
- ❖ Contouring of delay lines provides better coupling on curved surfaces
- ❖ Warm temperature delay lines (WTD) can be used for room temperature applications

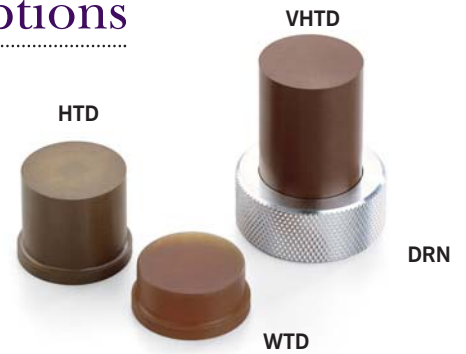

Special delay lines available for 1.25" and 1.50" element size

Transducer Nominal Element Size	Delay Line Retaining Ring	350°F max. (175°C)	500°F max. (260°C)	900°F max. (480°C)
1.00" 25mm	DRN - 3	WTD - 3-x	HTD - 3-x	VHTD - 3-x
0.75" 19mm	DRN - 4	WTD - 4-x	HTD - 4-x	VHTD - 4-x
0.50" 13mm	DRN - 5	WTD - 5-x	HTD - 5-x	VHTD - 5-x

*Recommended usage cycle is ten seconds maximum contact followed by one minute of air cooling. However, the transducer itself should not be heated above 122°F (50°C).

Note: X = standard delay line lengths, available in 1/2" (13mm), 1" (25mm), 1-1/2" (38mm). Specify at time of ordering.

Note: For the delay lines above, a room temperature material longitudinal wave velocity of 0.100 in/μsec ±0.005 in/μsec may be used as an approximation for basic calculations. This value should not be used for engineering design calculations. Contact us for details.

Protective Wear Cap Option

- ❖ The nylon wear cap provides an economical solution in applications requiring scanning or scrubbing of rough surfaces
- ❖ Contouring of wear caps provides better coupling on curved surfaces



Transducer Nominal Element Size	Protective Wear Caps
1.50" 38mm	NWC - 1
1.125" 29mm	NWC - 2
1.00" 25mm	NWC - 3
0.75" 19mm	NWC - 4
0.50" 13mm	NWC - 5

Protective Membrane Option

- ❖ Improves coupling on rough or uneven surfaces
- ❖ Dry couple to smooth, clean surfaces



Transducer Nominal Element Size	Membranes Only* (pkg of 12) (pkg of 60)	Membrane Retaining Ring	Kits (12 Membranes, 1 ring, C-2 couplant)
1.50" 38mm	PM-1-12 PM-1-60	MRN - 1	PMK - 1
1.125" 29mm	PM-2-12 PM-2-60	MRN - 2	PMK - 2
1.00" 25mm	PM-3-12 PM-3-60	MRN - 3	PMK - 3
0.75" 19mm	PM-4-12 PM-4-60	MRN - 4	PMK - 4
0.50" 13mm	PM-5-12 PM-5-60	MRN - 5	PMK - 5

*Available in 36" x 36" x 1/32" sheets. Order part number NPD-665-3101.

Immersion Transducers

An immersion transducer is a single element longitudinal wave transducer with a 1/4 wavelength layer acoustically matched to water. It is specifically designed to transmit ultrasound in situations where the test part is partially or wholly immersed.

Advantages:

- ❖ The immersion technique provides a means of uniform coupling
- ❖ Quarter wavelength matching layer increases sound energy output
- ❖ Corrosion resistant 303 stainless steel case with chrome-plated brass connectors
- ❖ Proprietary RF shielding for improved signal-to-noise characteristics in critical applications
- ❖ All immersion transducers, except paintbrush, may be focused spherically (spot) or cylindrically (line) (see Technical Notes page 40)
- ❖ Customer specified focal length concentrates the sound beam to increase sensitivity to small reflectors; many popular focal lengths are kept in stock
- ❖ Cylindrical contour correction reduces interface ringdown on tubing and bar stock

Applications:

- ❖ Automated scanning
- ❖ On-line thickness gaging
- ❖ High speed flaw detection in pipe, bar, tube, plate, and other similar components
- ❖ Time-of-flight and amplitude based imaging
- ❖ Thru-transmission testing
- ❖ Material analysis and velocity measurements

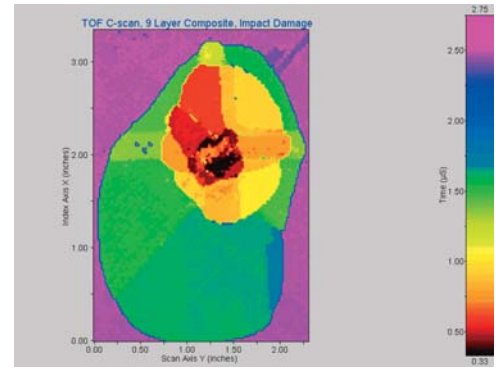
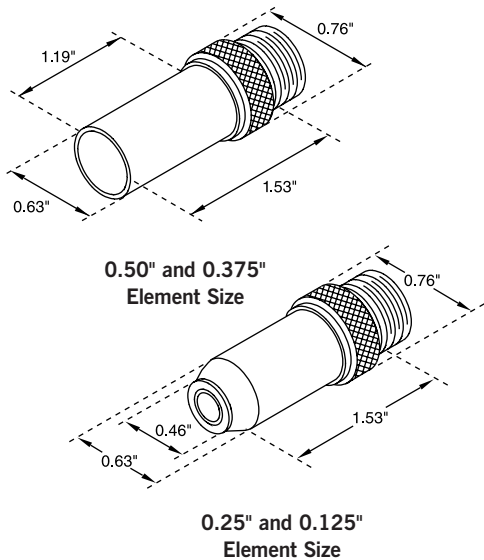

Standard Case Style

- ❖ Knurled case with Straight UHF connector (SU)
- ❖ Contact us for nonknurled case design and availability of other connector styles
- ❖ Frequencies ranging from 1.0-25MHz

Frequency MHz	Nominal Element Size	Transducer Part Numbers		
		ACCUSCAN-S	ACCUSCAN-R	VIDEOSCAN
1.0	0.50" 13mm	A303S-SU	A303R-SU	V303-SU
	0.50" 13mm	—	—	—
	0.375" 10mm	—	—	—
2.25	0.50" 13mm	A306S-SU	A306R-SU	V306-SU
	0.375" 10mm	—	—	V325-SU
	0.25" 6mm	—	—	V323-SU
3.5	0.50" 13mm	A382S-SU	A382R-SU	V382-SU
	0.375" 10mm	—	—	V383-SU
	0.25" 6mm	—	—	V384-SU
5.0	0.50" 13mm	A309S-SU	A309R-SU	V309-SU
	0.375" 10mm	A326S-SU	A326R-SU	V326-SU
	0.25" 6mm	A310S-SU	A310R-SU	V310-SU
7.5	0.50" 13mm	A320S-SU	A320R-SU	V320-SU
	0.50" 13mm	A311S-SU	A311R-SU	V311-SU
	0.375" 10mm	A327S-SU	A327R-SU	V327-SU
10	0.375" 10mm	A312S-SU	A312R-SU	V312-SU
	0.50" 13mm	A319S-SU	A319R-SU	V319-SU
	0.375" 10mm	—	—	V328-SU
15	0.25" 6mm	A313S-SU	A313R-SU	V313-SU
	0.25" 6mm	—	—	V317-SU
	0.125" 3mm	—	—	V316-SU
20	0.25" 6mm	—	—	V324-SU

Large Diameter Case Style

- ❖ Large element diameters increase near field length allowing for longer focal lengths
- ❖ Larger diameters can increase scanning index
- ❖ Low frequency, large aperture designs available for challenging applications

Frequency MHz	Nominal Element Size	Transducer Part Numbers		
		ACCUSCAN - S	ACCUSCAN - R	VIDEOSCAN
0.5	1.50" 38mm	A389S-SU	A389R-SU	V389-SU
	1.125" 29mm	A391S-SU	A391R-SU	V391-SU
	1.00" 25mm	A301S-SU	A301R-SU	V301-SU
	0.75" 19mm	—	—	V318-SU
1.0	1.50" 38mm	A392S-SU	A392R-SU	V392-SU
	1.125" 29mm	A394S-SU	A394R-SU	V394-SU
	1.00" 25mm	A302S-SU	A302R-SU	V302-SU
	0.75" 19mm	A314S-SU	A314R-SU	V314-SU
2.25	1.50" 38mm	A395S-SU	A395R-SU	V395-SU
	1.125" 29mm	A397S-SU	A397R-SU	V397-SU
	1.00" 25mm	A304S-SU	A304R-SU	V304-SU
	0.75" 19mm	A305S-SU	A305R-SU	V305-SU
3.5	1.00" 25mm	A380S-SU	A380R-SU	V380-SU
	0.75" 19mm	A381S-SU	A381R-SU	V381-SU
5.0	1.00" 25mm	A307S-SU	A307R-SU	V307-SU
	0.75" 19mm	A308S-SU	A308R-SU	V308-SU
7.5	0.75" 19mm	A321S-SU	A321R-SU	V321-SU
10	1.00" 25mm	—	—	V322-SU
	0.75" 19mm	A315S-SU	A315R-SU	V315-SU

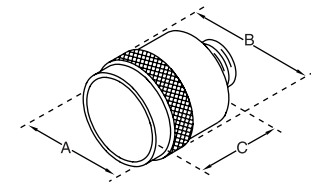

Nominal Element Size	(A)	(B)	(C)
1.50"	1.75"	1.81"	1.50"
1.125"	1.38"	1.44"	1.25"
1.00"	1.25"	1.31"	1.25"
0.75"	1.00"	1.06"	1.25"

Reflector Mirrors

- ❖ Directs sound beam when a straight-on inspection is not possible
- ❖ Standard mirrors provide a 90° reflection of the sound beam

Case Style	Incident Angle	Part Numbers
Standard	45°	F102
Slim Line	45°	F132
Pencil	45°	F198

Note: Contact us for other reflected angles.



Immersion Search Tubes

- ❖ Provides an easy and quick way to fixture and manipulate immersion transducers

Part Numbers	Length	Fits Connectors	Outside Diameter
		Styles	
F112	1.5" 38mm	UHF to UHF	0.738" 18.75mm
F113	2" 51mm	UHF to UHF	0.738" 18.75mm
F114	3" 76mm	UHF to UHF	0.738" 18.75mm
F115	6" 152mm	UHF to UHF	0.738" 18.75mm
F116	8" 203mm	UHF to UHF	0.738" 18.75mm
F117	12" 305mm	UHF to UHF	0.738" 18.75mm
F118	18" 457mm	UHF to UHF	0.738" 18.75mm
F119	24" 610mm	UHF to UHF	0.738" 18.75mm
F120	30" 762mm	UHF to UHF	0.738" 18.75mm
F211	12" 305mm	Microdot® to Microdot	0.312" 7.92mm

For more technical information please refer to the following pages:

Bubblers and Couplants page 30
 Theory on Focusing page 37-38
 Table of Near Field Distances page 40

Slim Line Case Style

- ❖ Stainless steel case is only 0.38" (10mm) in diameter, ideal for limited access areas
- ❖ Standard configuration is Straight and fits Microdot® connector style
- ❖ Available in 0.25" (6mm) and 0.125" (3mm) element diameters

Frequency MHz	Nominal Element Size	Transducer Part Numbers		
		ACCUSCAN-S	ACCUSCAN-R	VIDEOSCAN
2.25	0.25" 6mm	—	—	V323-SM
3.5	0.25" 6mm	—	—	V384-SM
5.0	0.25" 6mm	A310S-SM	A310R-SM	V310-SM
10	0.25" 6mm	A312S-SM	A312R-SM	V312-SM
15	0.25" 6mm	A313S-SM	A313R-SM	V313-SM
20	0.25" 6mm	—	—	V317-SM
	0.125" 3mm	—	—	V316-SM
25	0.25" 6mm	—	—	V324-SM

Pencil Case Style

- ❖ Small diameter, 2" (51mm) long barrel improves access to difficult-to-reach areas
- ❖ Standard connector style is Straight UHF Connector (SU)
- ❖ Ideal for applications such as bolt holes or the inside of tubes

Frequency MHz	Nominal Element Size	Transducer Part Numbers		
		ACCUSCAN-S	ACCUSCAN-R	VIDEOSCAN
2.25	0.25" 6mm	—	—	V323-N-SU
3.5	0.25" 6mm	—	—	V384-N-SU
5.0	0.25" 6mm	A310S-N-SU	A310R-N-SU	V310-N-SU
10	0.25" 6mm	A312S-N-SU	A312R-N-SU	V312-N-SU
15	0.25" 6mm	A313S-N-SU	A313R-N-SU	V313-N-SU
20	0.25" 6mm	—	—	V317-N-SU
	0.125" 3mm	—	—	V316-N-SU
25	0.25" 6mm	—	—	V324-N-SU

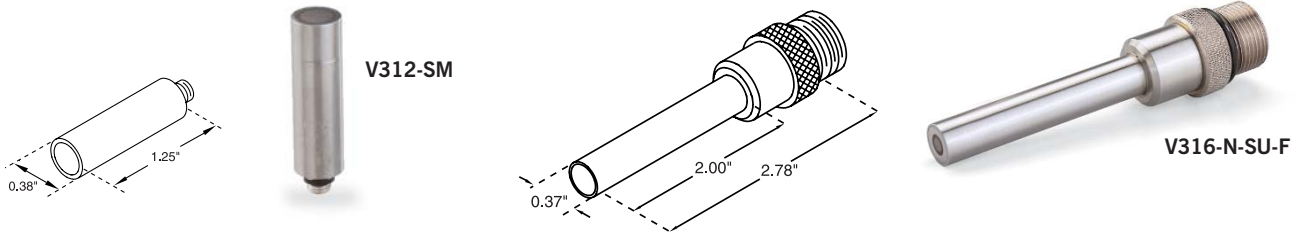

Accuscan Paintbrush

- ❖ Large scanning index is ideal for inspections of aluminum or steel plate
- ❖ Sensitivity uniformity of better than $\pm 1.5\text{dB}$ is maintained across the transducer face (sensitivity peaks at the edges are also controlled)

Frequency MHz	Nominal Element Size	Transducer Part Numbers
2.25	1.50" x 0.25" 38 x 6mm	A330S-SU
3.5		A331S-SU
5.0		A332S-SU
7.5		A333S-SU
10		A334S-SU
2.25	2.00" x 0.25" 51 x 6mm	A340S-SU
3.5		A341S-SU
5.0		A342S-SU
7.5		A343S-SU
10		A344S-SU

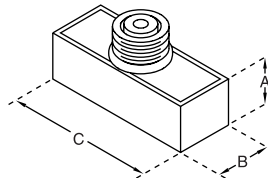

Nominal Element Size	(A)	(B)	(C)
2.00" x 0.25"	0.82"	0.75"	2.50"
1.50" x 0.25"	0.82"	0.75"	2.00"

Note: Certification of beam uniformity is included with each transducer.

For 7.5MHz and 10MHz, case height (A) is 0.62". 1 inch = 25.4mm.

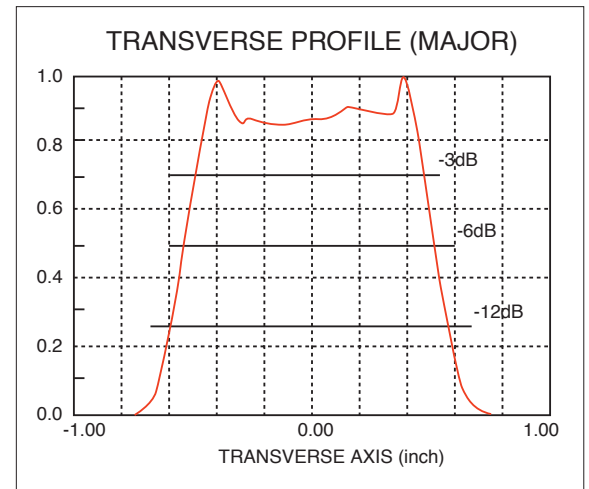

Normal Incidence Shear Wave Transducers

These single element contact transducers introduce shear waves directly into the test piece without the use of refraction.

Advantages:

- ❖ The ratio of the longitudinal to shear wave components is generally below -30dB
- ❖ Generate shear waves which propagate perpendicular to the test surface
- ❖ For ease of alignment, the direction of the polarization of shear wave is nominally in line with the right angle connector

Applications:

- ❖ Shear wave velocity measurements
- ❖ Calculation of Young's Modulus of elasticity and shear modulus (see Technical Notes page 38)
- ❖ Characterization of material grain structure

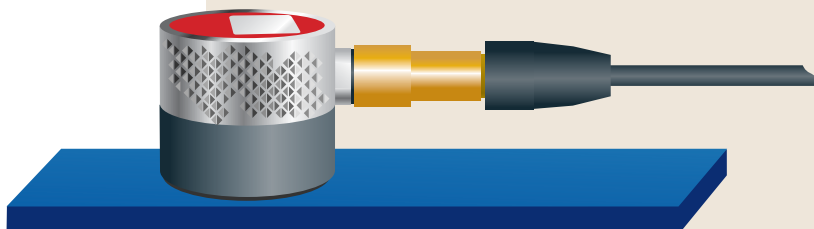

We recommend the use of our SWC shear wave couplant for general purpose testing.

Direct Contact Series

- ❖ WC-5 wear plate increases durability and wear resistance
- ❖ Available in both the Standard and Fingertip case styles
- ❖ 303 stainless steel case

Frequency MHz	Nominal Element Size		Transducer Part Numbers	
			Standard Case	Fingertip Case
0.1	1.00"	25mm	V1548	—
0.25	1.00"	25mm	V150 - RB	V150 - RM
0.5	1.00"	25mm	V151 - RB	V151 - RM
1.0	1.00"	25mm	V152 - RB	V152 - RM
	0.50"	13mm	V153 - RB	V153 - RM
2.25	0.50"	13mm	V154 - RB	V154 - RM
5.0	0.50"	13mm	V155 - RB	V155 - RM
	0.25"	6mm	—	V156 - RM
	0.125"	3mm	—	V157 - RM

For dimensions, see Contact Transducers on pages 4 and 5.



Delay Line Series

- ❖ Integral delay line permits measurements at higher frequencies
- ❖ Fused silica delay line minimizes attenuation and provides physical protection to the crystal element

Frequency MHz	Nominal Element Size		Delay μ sec	Transducer Part Numbers
5.0	0.25"	6mm	7	V220 - BA - RM
10	0.25"	6mm	7	V221 - BA - RM
20	0.25"	6mm	7	V222 - BA - RM
	0.25"	6mm	7	V222 - BB - RM
	0.25"	6mm	4	V222 - BC - RM

For dimensions, see High Frequency Transducers on page 20.



High Frequency Transducers

High frequency transducers are single element contact or immersion transducers designed to produce frequencies of 20MHz and greater.

Advantages:

- ❖ Heavily damped broadband design provides excellent time resolution
- ❖ Short wavelengths for superior flaw resolution capabilities
- ❖ Focusing allows for very small beam diameters
- ❖ Frequencies range from 20MHz to 225MHz

Applications:

- ❖ High resolution flaw detection such as inspection for microporosity or microcracks
- ❖ C-Scan imaging of surface breaking cracks or irregularities
- ❖ Thickness measurements of materials as thin as 0.0004" (0.01mm)*
- ❖ Examination of ceramics and advanced engineering materials
- ❖ Materials analysis

*Thickness range depends on material, transducer, surface condition, temperature, and setup selected.

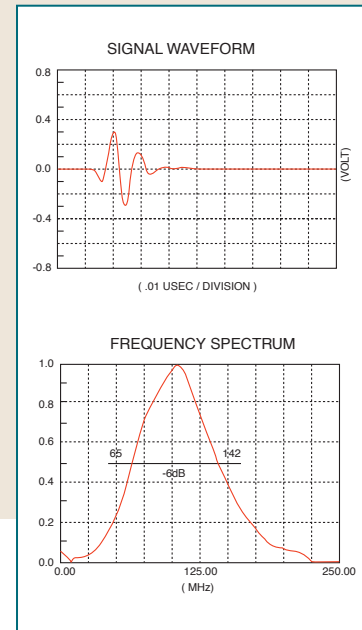

225MHz transducers are available as contact transducers. Performance is dependent on pulser/receiver and application. All transducers are manufactured on a special basis to customer specifications. Contact us to discuss applications.

High Frequency Contact Transducers

- ❖ Permanent fused silica delay line allows for flaw evaluation, material analysis or thickness measurements using a direct contact testing method
- ❖ Three different delay line configurations (BA, BB, BC) allow for various combinations of delay line echoes
- ❖ Standard connector style is Right Angle Microdot® (RM)

Frequency MHz	Nominal Element Size		Delay μ sec	Transducer Part Numbers
20	0.25"	6mm	4.25	V212 - BA - RM
	0.25"	6mm	4.25	V212 - BB - RM
	0.25"	6mm	2.5	V212 - BC - RM
30	0.25"	6mm	4.25	V213 - BA - RM
	0.25"	6mm	4.25	V213 - BB - RM
	0.25"	6mm	2.5	V213 - BC - RM
50	0.25"	6mm	4.25	V214 - BA - RM
	0.25"	6mm	4.25	V214 - BB - RM
	0.25"	6mm	2.5	V214 - BC - RM
	0.125"	3mm	4.25	V215 - BA - RM
	0.125"	3mm	4.25	V215 - BB - RM
	0.125"	3mm	2.5	V215 - BC - RM
75	0.25"	6mm	2.5	V2022 (BC)
	0.125"	3mm	2.5	V2025 (BC)
100	0.125"	3mm	4.25	V2054 (BA)
	0.125"	3mm	2.5	V2012 (BC)
125	0.125"	3mm	2.5	V2062

Please contact us for transducers in higher frequencies.

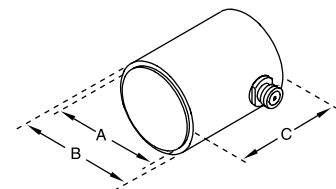

Delay Style	(A)	(B)	(C)
BA	0.72"	0.81"	1.00"
BB	0.34"	0.44"	0.81"
BC	0.34"	0.44"	0.63"

1 inch = 25.4mm

High Frequency Standard Immersion Case Style

- ❖ Permanent internal delay line
- ❖ Focused units use an optical quality ground lens
- ❖ F202 adaptor allows fixturing with a passive UHF connector and an active Microdot® style connector (see page 29)
- ❖ Combines high frequency with a small case design

Frequency MHz	Nominal Element Size		Delay μ sec	Focal Length		Transducer Part Numbers
20	0.25"	6mm	4.25	flat		V354-SU
	0.25"	6mm	2.5	0.75"	19mm	V372-SU
	0.25"	6mm	4.25	1.25"	32mm	V373-SU
	0.25"	6mm	4.25	2.00"	51mm	V374-SU
30	0.25"	6mm	4.25	flat		V356-SU
	0.25"	6mm	2.5	0.75"	19mm	V375-SU
	0.25"	6mm	4.25	1.25"	32mm	V376-SU
	0.25"	6mm	4.25	2.00"	51mm	V377-SU
50	0.25"	6mm	4.25	flat		V358-SU

V358-SU



V358-SU with F202 adaptor

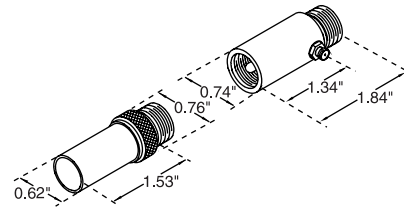

High Frequency SU/RM Immersion Case Style

- ❖ Permanent fused silica delay with an optical quality ground lens provides a high degree of precision in beam alignment and focusing
- ❖ Stainless steel case has a passive Straight UHF (SU) connector and an active Right Angle Microdot (RM) connector
- ❖ Large cases allow for larger delay lines and decrease in delay reverberations and noise

Frequency MHz	Nominal Element Size		Delay μ sec	Focal Length		Transducer Part Numbers
50	0.25"	6mm	19.5	0.50"	13mm	V390-SU/RM
	0.25"	6mm	19.5	0.75"	19mm	V3192
	0.25"	6mm	19.5	1.00"	25mm	V3193
	0.25"	6mm	19.5	1.75"	45mm	V3409
	0.25"	6mm	19.5	2.00"	51mm	V3337
	0.25"	6mm	9.4	0.20"	5mm	V3330*
	0.125"	3mm	19.5	0.50"	13mm	V3332
75	0.25"	6mm	19.5	0.50"	13mm	V3320
	0.25"	6mm	19.5	0.75"	19mm	V3349
90	0.25"	6mm	19.5	0.50"	13mm	V3512
100	0.25"	6mm	19.5	0.50"	13mm	V3194
	0.25"	6mm	19.5	1.00"	25mm	V3394
	0.25"	6mm	9.4	0.20"	5mm	V3534*
	0.125"	3mm	10.0	0.25"	6mm	V3346

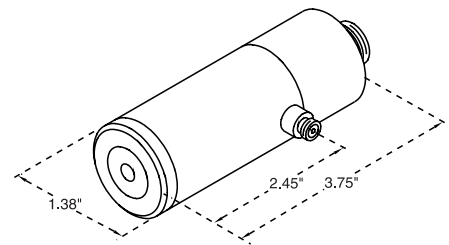

V3194 with F109 transformer



*Transducers create surface waves in steel, titanium and other materials with similar velocities. Please contact us for higher frequency. Lightweight High Frequency are an alternative to the SU/RM case style transducers. They offer a smaller case width and lighter weight without sacrificing performance.

Special Transducers

RTD Transducers

RTD Transducers are well known in the nuclear industry for inspection of critical weld areas in pipes and pressure vessels. We are the exclusive North American Representative for this special line of transducers manufactured by RTD in the Netherlands. The realm of applications for these transducers is extensive: inspection

of coarse grain austenitic steel, location of undercladding cracks, detection and sizing of IGSCC, automated scanning of pipe and pressure vessels, and continuous high temperature applications.



CDS Wedges

CDS Wedges are used in the "30-70-70" technique for crack detection and sizing. They are compatible with our replaceable miniature screw-in angle beam transducers, making them an economical alternative to other commercially available products. Ask for Transducer Update #10.



Captive Water Column Transducers

Captive Water Column Transducers incorporate a replaceable pliable membrane which holds a small column of water in front of a flat or focused immersion transducer. The membrane will conform to the concave surface of the test piece. One of the most common applications for these transducers is spot weld evaluation. Replaceable delay lines may be purchased for use with these transducers in spot weld or other special applications. Delays may be modified upon request to fit specific sizes required. Ask for Spotweld Application Note.

Delay Line Transducers with Handle Assembly

These transducers are used to reach into areas of limited access such as adjacent turbine blades. The swivel head improves contact in tight areas.



Handheld Bubbler Transducer Assembly

Handheld bubbler transducers are available in either 20MHz (V316B) or 10MHz (V312B). They are immersion transducers that screw onto a bubbler (B120) which has a replaceable stainless steel tip. They offer high resolution and easy access inspection of thin materials. The V316B and bubbler

combination can resolve thicknesses down to 0.008" (0.2mm). For more information, ask for Transducer Update #8A.



Low Frequency Narrowband Transducers

Meant for use in pairs for through transmission in materials such as concrete, wood, and geological samples, these are available in frequencies of 50KHz (X1021), 100KHz (X1020), and 180KHz (X1019). Recommended instruments are high voltage pulser-receivers such as the Model 5058PR.



500KHz Broadband/Highly Damped Transducers

This highly damped transducer measures the thickness of fiberglass, composites, and other attenuating materials. This transducer can also be used with a NWC-302 Nylon Wear Cap for flaw detection on thick or rough surfaced casting materials.



Magnetic Hold-Down Transducers

Incorporated in this transducer design is a magnetic ring around the case for stationary hands-free positioning on ferrous structures. These transducers are available in several frequencies and case sizes with newly designed magnetic rings for stronger coupling.



Combination Longitudinal/ Shear Mode Transducers

These transducers generate simultaneous longitudinal waves and shear waves in either single element, dual element or three element arrangement. They can be custom designed for different frequencies and element sizes.



Radiation Resistant Transducers

Designed to withstand radiation up to 100 Mrad total integrated radiation dose, these immersion transducers have an integral potted cable and can be ordered either focused or flat.

Polymer Transducers

Polymer transducers have become more popular in recent years due to their inherent broadband characteristic which results in a comparatively higher resolution transducer. Furthermore, the close impedance match of polymers to water produces a better transfer of sound energy. One of the major advantages of high frequency polymer transducers is the elimination of permanent delay lines and their associated echoes.



Extra Miniature (XMS) Transducer

The XMS transducer is an extremely small immersion transducer with a 3mm (0.118") diameter by 3mm (0.118") long case. This transducer is ideal for extremely tight access areas or for multi-element array flaw detection. The transducer assembly has a special connector attached to the 1m (38") long potted cable. An adaptor is also available to interface with most commercial ultrasonic equipment.



Continuous High Temperature Delay Line Transducers

These transducers can continuously withstand temperatures as high as 350°F (175°C) and pressures up to 85 PSIG. One typical application is to monitor the cure of materials in autoclave.



Variable Angle Beam Wedge

The Variable Angle Beam Wedge allows the user to adjust the incident angle from 0° to 50° to create refracted angles in steel from 0° to 90°. The wedge is to be used with the 0.50" x 1.00" Standard Angle Beam Transducers (see page 10).

Miniature Screw-In and Snap-In Wedges for 2.25MHz Transducers

Typically, Snell's Law is used in the design of angle beam wedges. However, Snell's Law fails as a design rule at high angles of incidence/refraction with lower frequency smaller diameter transducers. For this reason, we offer the following Miniature Screw-In and Snap-In Wedges. We recommend the use of these wedges when using transducers that are 2.25MHz or less and it is important to account for the slight difference in refracted angle.

Nominal Element Size	Wedge Part Numbers			
	Screw-In		Snap-In	
	60°	70°	60°	70°
0.50" 13mm	ABWM-5082T	ABWM-5083T	ABWM-5081	ABWM-5080
0.25" 6mm	ABWM-4119T	ABWM-4120T	ABWM-4069	ABWM-4070



Electromagnetic Acoustic Transducer (EMAT)

Electromagnetic Acoustic Transducers are single element transducers that employ a magnetostrictive effect to transmit and receive ultrasonic waves.

Advantages:

- No need to remove external scale
- No couplant required
- Use in contact with or at a small distance from surface
- Can be used at elevated material temperatures*
- Can be used on small diameter pipes
- Metal ring protects wear surface and is adjustable for optimal magnetic field levels

Applications:

- External oxide scaled surfaces
- Small diameter scaled pipes
- High temperature applications
- Use with 37DL PLUS thickness gage or EPOCH 4PLUS flaw detector

Part Number

E110-SB

*Temperature specification are 32° – 140°F (0° - 60°C) for continuous contact, and 175°F (80°C) for intermittent contact, defined as 10 seconds in contact with part and 60 seconds of cooling time.

Test Blocks

Calibration and/or Reference Blocks should be used in every application. Standard blocks are available for angle beam calibrations and thickness calibrations of common materials.

- ❖ Blocks can be manufactured in a variety of materials
- ❖ Replace the "X" in the part number with the appropriate number listed below to signify block material:
 - 1 = 1018 Steel
 - 2 = 4340 Steel
 - 4 = 7075-T6 Aluminum
 - 5 = 304 Stainless Steel
 - 8 = 6-4 Titanium
- ❖ Blocks manufactured from 1018 steel, 304 stainless steel, or 7075-T6 aluminum are commonly in stock. Other materials require special quotes for price and delivery
- ❖ Contact us for more information regarding materials not listed, blocks not listed, or custom blocks.

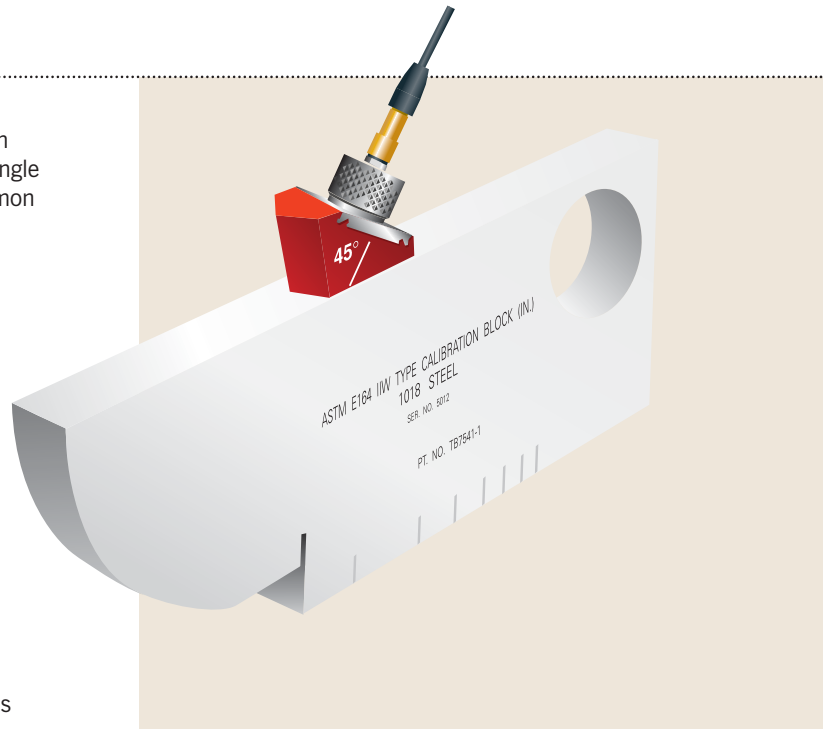

Calibration Blocks

All blocks are checked dimensionally using measuring equipment traceable to the National Institute of Standards and Technology, NIST. The most commonly required calibration blocks are listed below.

Type	Part Number	Hardwood Case	Description
ASTM E164 Calibration IIW-Type Block	TB7541-x	F129	Meets AASHTO and AWS Type 1 block requirements. Calibrate distance and sensitivity settings. Measure refracted angle and sound exit point of angle beam transducers. U.S. customary units (inches).
	TB1054-x	F129	Metric Units
US Air Force IIW-2 Calibration Block	TB5939-x	F129	IIW-type block per U.S. Air Force NDI Manual T.O. 33B-1-1. Includes 2" and 4" radius cutouts for distance calibration. No. 3, No. 5 and No. 8 side drilled holes, and distance calibration marks to the 2" hole.
RC AWS Block	TB7543-x	F157	Determining resolution capabilities of angle beam transducers per AWS and AASHTO requirements.
SC AWS Block	TB7545-x	F158	Sensitivity and refracted angle calibration per AWS and AASHTO requirements.
DC AWS Block	TB7547-x	F159	Distance and beam index calibration for angle beam transducers per AWS and AASHTO requirements.
DSC AWS Block	TB7549-x	F160	Distance, sensitivity, refracted angle and beam index calibration for angle beam transducers per AWS and AASHTO requirements.
DS AWS Block	TB7551-x	F161	Calibration block for horizontal linearity and dB accuracy procedures per AWS and AASHTO requirements.
30FBH Resolution Reference Block	TB7160-x	Included	Evaluate near surface resolution and flaw size/depth sensitivity of UT equipment. No. 3, No. 5 and No. 8 ASTM flat bottom holes at ten metal travel distances from 0.050" to 1.250".
NAVSHIPS Block	TB7567-x	F162	Contains six No. 3 side drilled holes. Used for distance-amplitude calibration per NAVSHIPS 0900-006-3010.
ASTM E164 MAB Block	TB7150-x	F197	Miniature Angle Beam (ROMPAS) Block. Distance, beam index, refracted angle and sensitivity calibration. One inch thick.
ISO 7963 Steel	TB1065-x	F197	Miniature Angle Beam Block Distance, beam index, refracted angle and sensitivity calibration. 25mm thick.

Reference Blocks

We offer commonly used sets of reference blocks recommended by ASTM standards. These sets are all manufactured to ASTM E127 and ASTM E428 physical dimensions requirements. All reference blocks are provided with an ultrasonic response curve. We can provide,

by special order, materials not listed and individual reference blocks. Contact us for more information regarding materials not listed, custom calibration blocks, or quotations on blocks not listed in this section.

Type of Set*	Part Number	Description of Set
Distance-Area Amplitude Set	TB6100-X	Set of 10 ASTM blocks per US. Air Force NDI Manual T.O. 33B-1-1. Dead zone, sensitivity, distance and area amplitude linearity measurements. Flat bottom hole sizes and metal travel distances (inches) for this Basic Set per E127 Table 1 are: 3/64 at 3 5/64 at 1/8, 1/4, 1/2, 3/4, 1-1/2, 3, 6 8/64 at 3, 6
Area-Amplitude Set	TB6200-X	Set of 8 ASTM blocks used to determine the relationship between flaw size and echo amplitude by comparing signal responses. Metal travel distance is 3 inches in all 8 blocks. Flat bottom hole diameters (inches) for this Area-Amplitude Set per E127 Table 3 are: 1/64 2/64 3/64 4/64 5/64 6/64 7/64 8/64
Distance-Amplitude Set-No. 3FBH	TB6303-X	Set of 19 ASTM blocks all having the same flat bottom hole size. The relationship between metal distance and signal amplitude is determined by comparing the signal responses obtained. Metal travel distances (inches) selected from E127 Table 4 for the Distance-Amplitude Set are:
Distance-Amplitude Set-No. 5FBH	TB6305-X	1/16 1/2 1 2-1/4 3-1/4 4-1/4 5-1/4 1/8 5/8 1-1/4 2-3/4 3-3/4 4-3/4 5-3/4
Distance-Amplitude Set-No. 8FBH	TB6308-X	1/4 3/4 1-3/4 3/8 7/8
Sensitivity-Resolution Set	TB6025-X	Set of 9 ASTM blocks and one special rectangular block used to evaluate the sensitivity, entry surface resolution, and horizontal/vertical linearity characteristics of UT equipment per ASTM E317. Flat bottom hole sizes and metal travel distances (inches) are: 1/64 at 3 2/64 at 3 5/64 at 1/8, 1/4, 3/8, 1/2, 3/4, 1, 1-1/2

*Includes Hardwood case.

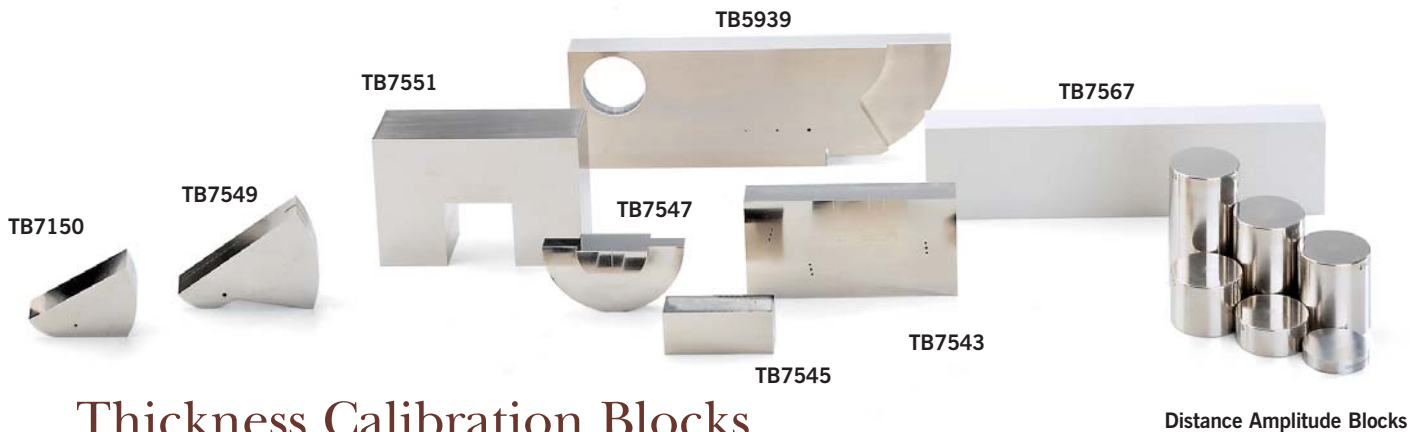

Thickness Calibration Blocks

❖ Blocks are held to tighter tolerances than called out in ASTM E797 Code.

Part Numbers	Material	Steps
2211E	304 Stainless Steel	0.100", 0.200", 0.300", 0.400", and 0.500"
2211M	304 Stainless Steel	2.5mm, 5.0mm, 7.5mm, 10.0mm, 12.5mm
2212E	1018 Carbon Steel	0.250", 0.500", 0.750", and 1.00"
2212M	1018 Carbon Steel	6.25mm, 12.5mm, 18.75mm, and 25mm
2213E	7075-T6 Aluminum	0.100", 0.200", 0.300", 0.400", and 0.500"
2213M	7075-T6 Aluminum	2.5mm, 5.0mm, 7.5mm, 10.0mm, 12.5mm
2214E	1018 Carbon Steel	0.100", 0.200", 0.300", 0.400", and 0.500"
2214M	1018 Carbon Steel	2.5mm, 5.0mm, 7.5mm, 10.0mm, 12.5mm

Note: For hardwood case, order 2214C.

Cables and Adaptors

- ❖ Select from a variety of cable grades to meet your specific application needs
- ❖ Standard lengths 3' (1m), 4' (1.2m), 6' (1.8m). When ordering, replace the X in the part number with the desired cable length in feet
- ❖ Custom cable lengths are available, please specify when ordering
- ❖ Part numbering prefix indicates connector style for both ends of the cable
- ❖ Contact us for special or customized cables

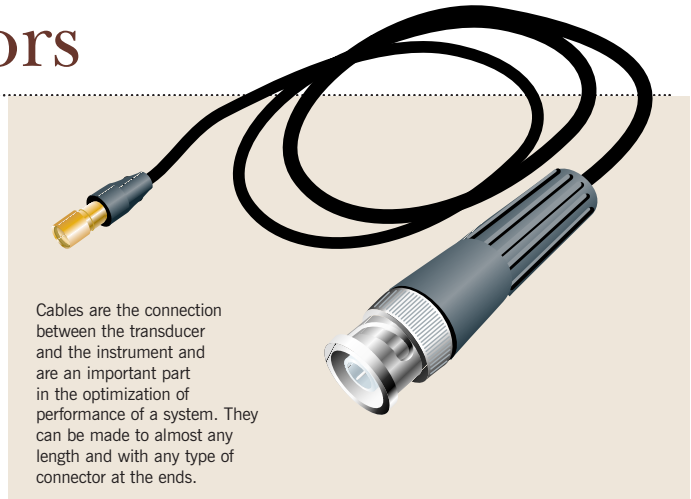

Standard

Cable Part Numbers	Fits Connector Style
BCB-58- x	Fits BNC to BNC
BCB-74- x	Fits BNC to BNC
BCM-74- x	Fits BNC & Microdot®
BCMA-74- x	Fits BNC & Microdot without Boot
BCRM-74- x	Fits BNC & Right Angle Microdot
BCU-58- x	Fits BNC to UHF
BCU-62- x	Fits BNC to UHF
FLCB-74- x	Fits Female Lemo® & BNC
LCB-74- x	Fits Small Lemo 00 & BNC
LCM-74- x	Fits Small Lemo 00 & Microdot
LCU-74- x	Fits Small Lemo 00 & UHF
L1CB-58- x	Fits Large Lemo1 & BNC
L1CM-74- x	Fits Large Lemo1 & Microdot
L1CU-74- x	Fits Large Lemo1 & UHF
L1CU-74- x	Fits Large Lemo1 & UHF
UCM-74- x	Fits UHF & Microdot
UCU-58- x	Fits UHF to UHF

Heavy Duty (HD)

- ❖ External teflon coating provides flexibility and improved cable performance in industrial settings

Cable Part Numbers	Fits Connector Style
BCB-188- x HD	Fits BNC to BNC
BCM-188- x HD	Fits BNC & Microdot
BCU-188- x HD	Fits BNC to UHF
LCB-188- x HD	Fits Small Lemo 00 & BNC
LCM-188- x HD	Fits Small Lemo 00 & Microdot

Microdot® is registered trademark of Microdot, Inc.
LEMO® is registered trademark of Interlemon Holding SA.

Armored Stainless Steel (SSA)

- ❖ Interlocking stainless steel jacket provides flexibility, protection and ruggedness in heavy industrial settings
- ❖ Can be ordered in lengths up to 25 feet (8m)

Cable Part Numbers	Fits Connector Style
BCB-188- x SSA	Fits BNC to BNC
BCM-188- x SSA	Fits BNC and Microdot
BCRM-188- x SSA	Fits BNC and Right Angle Microdot
BCU-188- x SSA	Fits BNC to UHF
LCM-188- x SSA	Fits Small Lemo 00 & Microdot
LCRM-188- x SSA	Fits Small Lemo 00 & Right Angle Microdot

Double Shielded (DS)

- ❖ Additional grounded shield provides low cable noise for better performance in high frequency applications
- ❖ 15 ohm or 25 ohm cable of different lengths may help to optimize high frequency system performance

Cable Part Numbers	Fits Connector Style
BCM-74- x DS	Fits BNC & Microdot
BCM-15- x DS	Fits BNC & Microdot
BCM-25- x DS	Fits BNC & Microdot

Cables with Handle

- ❖ Special 3" (75mm) long reinforced handle for increased durability and easier grip
- ❖ Custom handles can be ordered 6" (152mm), 9" (229mm), and 12" (305mm) in length

Cable Part Numbers	Fits Connector Style
BCMH-74- x	Fits BNC & Microdot
LCMH-74- x	Fits Small Lemo 00 & Microdot
L1CMH-74- x	Fits Large Lemo1 & Microdot

Waterproof

- ❖ Specially designed proprietary waterproof UHF connector provides a waterproof connection good to depths of about 150 feet (50m) in fresh water.

Cable Part Numbers	Fits Connector Style
BCM-74- x W BCRM -74- x W BCU-58- x W BCU-62- x W BCU-74- x W	Fits BNC to Microdot® Fits BNC to Right Angle Microdot Fits BNC to UHF Fits BNC to UHF Fits BNC to UHF
LCM-74- x W LCU-74- x W L1CU-74- x W	Fits Small Lemo® 00 to Microdot Fits Small Lemo 00 to UHF Fits Large Lemo 1 to UHF

Adaptors

Part Numbers	Fits Connector Style
F108 F195 F202	Right Angle UHF Male to UHF Female, waterproof 45° UHF Female to UHF Male Active UHF Female to Passive UHF Male/Active Right Angle Microdot Female (see page 21).
F206 F267	UHF to Flange Right Angle UHF Female to UHF Male, waterproof
BF-BF BM-BM BM-UF L1F-BM L1M-BF LM-BF LF-BM	BNC Female to BNC Female BNC Female to BNC Female BNC Male to UHF Female Lemo 1 Female to BNC Male Lemo 1 Male to BNC Female Lemo 00 Male to BNC Female Lemo 00 Female to BNC Male
MM-UMW UM-BF LF-UM MM-UFW	Microdot Male to UHF Male, waterproof UHF Male to BNC Female Lemo 00 Female to UHF Male Microdot Male to UHF Female, waterproof



Dual

- ❖ Single cable design with two connectors at each end to fit dual element transducers

Cable Part Numbers	Fits Connector Style	Compatible With
BCMD-74-6 LCMD-74-6 L1CMD-74-6	Dual BNC to Microdot Dual Small Lemo 00 to Microdot Dual Large Lemo1 to Microdot	Standard Dual Transducer
BCMD-316-5B L1CMD-316-5B	Dual BNC to Microdot Dual Large Lemo1 to Microdot	D790-SM Transducer
BCMD-316-5F L1CMD-316-5F	Dual BNC to Microdot Dual Large Lemo1 to Microdot	DHC Dual Transducer
BCLPD-78-5 L1CLPD-78-5	Dual BNC to Lepra Con Dual Large Lemo1 to Lepra Con	MTD-705 Transducer
LCLD-316-5G* LCLD-316-5H LCLPD-78-5 LCMD-316-5B* LCMD-316-5C LCMD-316-5D LCMD-316-5J	For 26, 36 and 37 series thickness gages	D790-RL D790-SL MTD-705 D790-SM D791-RM D797-SM D798-SM
BCSD-74-6 LCS-74-6	Dual BNC to Sealelectro Dual Small Lemo 00 to Sealelectro	D769 and D770

*Stainless steel cable available.

Heavy Duty, Armored PVC (HDAP)

- ❖ Spiral stainless steel jacket with external solid PVC coating makes this cable very durable

Cable Part Numbers	Fits Connector Style
BCB-188- x HDAP BCM-188- x HDAP BCU-188- x HDAP	Fits BNC to BNC Fits BNC to Microdot Fits BNC to UHF
LCB-188- x HDAP LCM-188- x HDAP	Fits Small Lemo 00 to BNC Fits Small Lemo 00 to Microdot

Heavy Duty, Armored Super Flexible Silicone (HDAS)

- ❖ Stainless steel jacket with an external silicone coating makes this cable durable, yet flexible

Cable Part Numbers	Fits Connector Style
BCB-188- x HDAS BCM-188- x HDAS BCU-188- x HDAS	Fits BNC to BNC Fits BNC to Microdot Fits BNC to UHF
LCB-188- x HDAS LCM-188- x HDAS	Fits Small Lemo 00 to BNC Fits Small Lemo 00 to Microdot

Bubblers and Couplants

Bubblers

- ❖ Allows for immersion testing when complete immersion of parts is not desirable or possible
- ❖ Designed to maintain a consistent, low volume flow of water

Part Numbers	Opening	Water Path	Case Style
MPF-B-0.5	0.300" (7.6mm)	1.00" (25.4mm)	Fits 0.125" (3mm) and 0.25" (6mm) standard immersion case
B103*	0.350" (8.9mm)	0.775" (19.9mm)	Fits 0.125" (3mm) and 0.25" (6mm) standard immersion case
B103A*	0.350" (8.9mm)	0.475" (12.1mm)	Fits 0.125" (3mm) and 0.25" (6mm) standard immersion case
B103W	0.550" (14mm)	0.775" (19.7mm)	Fits 0.375" (10mm) and 0.50" (13mm) standard immersion case
B103AW*	0.550" (14mm)	0.475" (12.1mm)	Fits 0.375" (10mm) and 0.50" (13mm) standard immersion cases
B116	0.100" (2.5mm)	variable, min of 0.075" (1.9mm)	Fits SU/RM case style (see page 21)
B117	1.375" (34.3mm)	1.400" (35.6mm)	Fits 1.00" (25.4mm) large diameter immersion case style

Note: The B103 and B103W have a V-notch shaped opening, the B103A and B103AW are flat. All four can be used with the RBS-1 Recirculating Bubbler System.



Ultrasonic Couplants

Part Numbers	Description	Volume	Application
A2	Propylene Glycol	2 oz. (0.06 liter)	General purpose couplant for smooth surfaces Chemically non-reactive, does not evaporate quickly The max. recommended temp. is 200°F (90°C)
AP	Propylene Glycol	1 pt. (0.47 liter)	
AQ	Propylene Glycol	1 qt. (0.95 liter)	
AG	Propylene Glycol	1 gal. (3.78 liter)	
B2	Glycerin	2 oz. (0.06 liter)	General purpose, more viscous and has a high acoustic impedance making it the preferred couplant for rough surfaces and highly attenuating materials
BQ	Glycerin	1 qt. (0.95 liter)	
C2	Silicone Oil	2 oz. (0.06 liter)	General purpose, non-corrosive, does not evaporate and is insoluble in water
D12	Gel Type	12 oz. (0.35 liter)	Rough surfaces such as sand-cast metals and fiberglass layups Weld inspections, overhead surfaces or vertical walls
DG	Gel Type	1 gal. (3.78 liter)	
D-5G	Gel Type	5 gal. (18.90)	
E-2	Ultratherm	2 oz. (0.06 liter)	500°F to 1000°F (260°C to 540°C) 32°F to 540°F (0°C to 280°C) Remains a stable liquid or paste form, without boiling off.
F-2	Medium Temp	2 oz. (0.06 liter)	
G-2	Medium Temp	2 oz. (0.06 liter)	0°F to 600°F (-12° to 315°C) Easy removal at high temperatures. Non-toxic and biodegradable
SWC	Shear Wave	4 oz. (0.12 liter)	Normal Incidence Shear Wave, non-toxic, water soluble organic substance of very high viscosity
HP-G	Powdered Couplant	makes 1 gal (3.78 liter)	Bulk Couplant Customize the viscosity by adding different amounts of water. Temperature range for this couplant is 32 to 130° F (0 to 54° C). Can be winterized by mixing with windshield washer fluid.
HP-G-C	Powdered Couplant with Corrosion Inhibitor	makes 1 gal (3.78 liter)	

Test and Documentation

We are an active leader in the development of transducer characterization techniques and has participated in the development of the AIUM Standard Methods for Testing Single Element Pulse-Echo Ultrasonic Transducers as well as ASTM-E 1065 Standard Guide for Evaluating Characteristics of Ultrasonic Search Units. In addition, we have performed characterizations according to AWS, ESI, and many other industrial and military standards. All equipment in our Transducer Test Lab is maintained in compliance with MIL-C-45662A Calibration System

Requirements. As part of the documentation process an extensive database containing records of the waveform and spectrum of each transducer is maintained and can be accessed for comparative or statistical studies of transducer characteristics. Our Test Lab offers a variety of documentation services including waveform and spectrum analysis, axial and transverse beam profiles, beam alignment measurements, and electrical impedance plots. Please consult us concerning special testing requirements.

Standard Test Forms (TP103)

The TP103 Standard Test Form is supplied at no charge with the purchase of every Accuscan and Videoscan Transducer. This form records the actual RF waveform and frequency spectrum for each transducer. Measurements of peak and center frequency, upper and lower -6dB frequencies, bandwidth, and waveform duration are made according to ASTM-E 1065 and are tabulated on the test form.

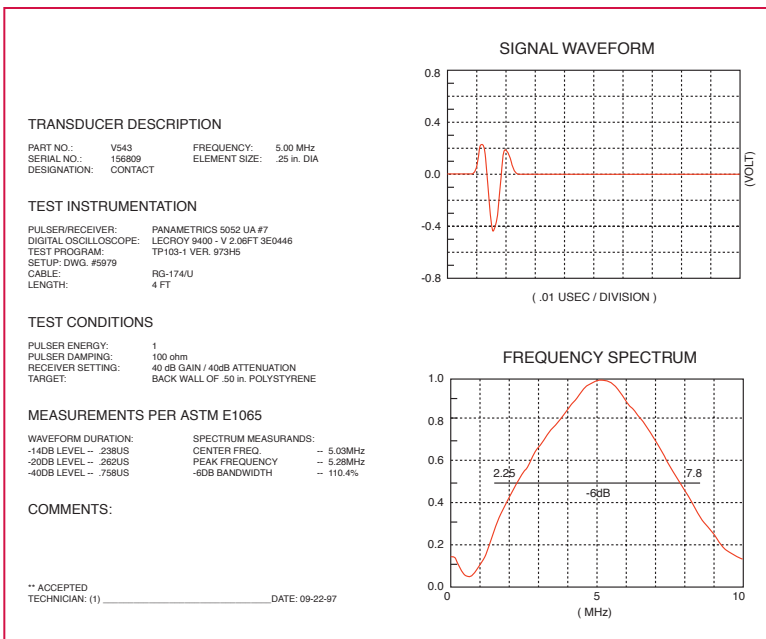

TP101

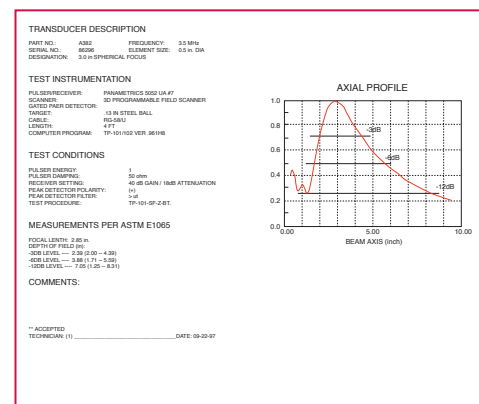

TP102

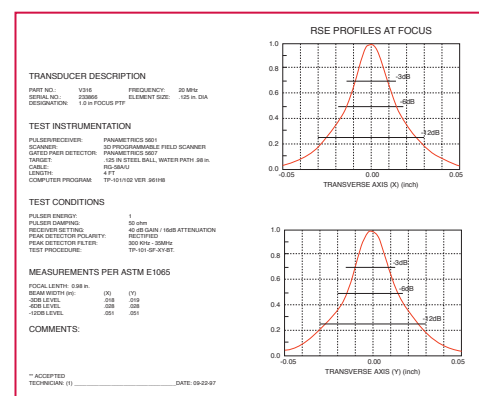

Beam Profiles (TP101 and TP102)

Beam profiles provide valuable information about transducer sound field characteristics. Transverse beam profiles are created by scanning the transducer across a target (usually either a steel ball or rod) at a given distance from the transducer face and are used to determine focal spot size and beam symmetry. Axial beam profiles are created by recording the pulse-echo amplitude of the sound field as a function of distance from the transducer face and provide data on depth of field and focal length.

Electrical Impedance Plots (TP104)

Electrical impedance plots provide important information about the design and construction of a transducer and can allow users to obtain electrically similar transducers from multiple sources.

Beam Alignment Measurements (TP110A)

Beam alignment measurements provide data on the degree of alignment between the sound beam axis and the transducer housing. This information is particularly useful in applications that require a high degree of certainty regarding beam positioning with respect to a mechanical reference surface.